



-power in control



## DESIGNER'S REFERENCE HANDBOOK



### Multi Differential Relay, MDR-2

- Differential current protection, generator or electric motor



DEIF A/S · Frisenborgvej 33 · DK-7800 Skive  
Tel.: +45 9614 9614 · Fax: +45 9614 9615  
info@deif.com · www.deif.com

Document no.: 41893403001  
SW version:

## 1. General information

1.1. Warnings, legal information and safety.....	4
1.1.1. Warnings and notes .....	4
1.1.2. Legal information and disclaimer .....	4
1.1.3. Safety issues .....	4
1.1.4. Electrostatic discharge awareness .....	4
1.1.5. Factory settings .....	5
1.2. About the Designer's Reference Handbook.....	5
1.2.1. General purpose .....	5
1.2.2. Intended users .....	5
1.2.3. Contents and overall structure .....	5

## 2. Preface

2.1. General data.....	6
2.1.1. Technical specifications .....	6

## 3. Standard functions

3.1. Differential current detection.....	7
3.1.1. Differential current tripping/warning .....	8
3.2. Display.....	8
3.2.1. Panel cutout for display .....	10
3.2.2. Unit dimensions in mm (inches).....	11

## 4. Hardware

4.1. Terminals and board slot positions.....	12
4.2. Base unit LED indicators.....	12
4.3. Terminal strip overview.....	14
4.3.1. Slots #1, #2, #5 and #6 .....	14
4.3.2. Slots #3, #4, #7 and #8 .....	15
4.4. Terminal strip, explanation.....	15
4.4.1. Slot #1, power supply and digital I/O .....	16
4.4.2. Slot #7, AC current measurement .....	17

## 5. Wiring diagrams

5.1. Coupling and connection.....	18
5.1.1. AC current measurements, star coupling.....	18
5.1.2. AC current measurements, delta coupling .....	19
5.1.3. DC connections, inputs and outputs .....	20

## 6. Parameter programming

6.1. Programming.....	21
6.1.1. About programming.....	21
6.1.2. Parameter setting method in display .....	21
6.2. Differential current.....	21
6.2.1. Settings .....	21
6.2.2. Warning (curve 1) .....	22
6.2.3. Trip (curve 2) .....	22
6.2.4. Trip (fixed trip value) .....	23
6.2.5. Use of relay outputs .....	23
6.3. Other settings.....	23
6.3.1. Status LED .....	23
6.3.2. Auto acknowledgement of alarms .....	23
6.3.3. Service menu .....	24
6.4. Nominal settings.....	24
6.4.1. Nominal current .....	24
6.4.2. Current transformers .....	24
6.4.3. Date and time (internal clock) .....	25
6.4.4. Power supply (battery) under-voltage alarm .....	25

6.4.5. User password for programming via display.....25  
6.4.6. Language selection .....26

# 1. General information

## 1.1 Warnings, legal information and safety

### 1.1.1 Warnings and notes

Throughout this document, a number of warnings and notes with helpful user information will be presented. To ensure that these are noticed, they will be highlighted as follows in order to separate them from the general text.

#### Warnings

 **Warnings indicate a potentially dangerous situation, which could result in death, personal injury or damaged equipment, if certain guidelines are not followed.**

#### Notes

 **Notes provide general information, which will be helpful for the reader to bear in mind.**

### 1.1.2 Legal information and disclaimer

DEIF takes no responsibility for installation or operation of the generator set. If there is any doubt about how to install or operate the engine/generator controlled by the Multi-line 2 unit, the company responsible for the installation or the operation of the set must be contacted.

 **The Multi-line 2 unit is not to be opened by unauthorised personnel. If opened anyway, the warranty will be lost.**

#### Disclaimer

DEIF A/S reserves the right to change any of the contents of this document without prior notice.

The English version of this document always contains the most recent and up-to-date information about the product. DEIF does not take responsibility for the accuracy of translations, and translations might not be updated at the same time as the English document. If there is a discrepancy, the English version prevails.

### 1.1.3 Safety issues

Installing and operating the Multi-line 2 unit may imply work with dangerous currents and voltages. Therefore, the installation should only be carried out by authorised personnel who understand the risks involved in working with live electrical equipment.

 **Be aware of the hazardous live currents and voltages. Do not touch any AC measurement inputs as this could lead to injury or death.**

### 1.1.4 Electrostatic discharge awareness

Sufficient care must be taken to protect the terminal against static discharges during the installation. Once the unit is installed and connected, these precautions are no longer necessary.

### 1.1.5 Factory settings

The Multi-line 2 unit is delivered from factory with certain factory settings. These are based on average values and are not necessarily the correct settings for matching the engine/generator set in question. Precautions must be taken to check the settings before running the engine/generator set.

## 1.2 About the Designer's Reference Handbook

### 1.2.1 General purpose

This Designer's Reference Handbook mainly includes functional descriptions, presentation of display unit and menu structure, information about the PID controller, the procedure for parameter setup and reference to parameter lists.

The general purpose of this document is to provide useful overall information about the functionality of the unit and its applications. This document also offers the user the information he needs in order to successfully set up the parameters needed in his specific application.



**Please make sure to read this document before starting to work with the Multi-line 2 unit and the genset to be controlled. Failure to do this could result in human injury or damage to the equipment.**

### 1.2.2 Intended users

This Designer's Reference Handbook is mainly intended for the panel builder designer in charge. On the basis of this document, the panel builder designer will give the electrician the information he needs in order to install the Multi-line 2 unit, for example detailed electrical drawings. In some cases, the electrician may use these installation instructions himself.

### 1.2.3 Contents and overall structure

This document is divided into chapters, and in order to make the structure simple and easy to use, each chapter will begin from the top of a new page.

## 2. Preface

### 2.1 General data

#### 2.1.1 Technical specifications

Accuracy	0.1 × IN < I < IN: 1 % of IN IN < I: 1 % of I (IN = 1 A or 5 A, I = measured value, secondary side of CT)
Operating temperature	-25 to 70 °C
Aux. supply	12/24 V DC nominal (8 to 36 V DC operational), max. 11 W consumption 0 V DC for 10 ms when coming from at least 24 V DC
Frequency	30 to 70 Hz
Measuring current	From current transformers .../1 A or .../5 A. Consumption max. 0.3 VA per phase.
Digital inputs	Input voltage 6 to 32 V DC. Impedance 2.4 kΩ, bi-directional.
Relay outputs	250 V/8 A or 24 V DC/1 A. Refer to actual description of I/Os.
Safety	To EN 61010-1 installation category (over-voltage category) III, 600 V, pollution degree 2
Galvanic separation	Between AC current and other I/Os: 3250 V AC – 50 Hz – 1 min.
EMC/CE	According to EN-61000-1/2/3/4 IEC 255-3
Material	All plastic parts are self-extinguishing to UL94 (V1)
Climate	HSE, to DIN 40040
Connections	AC currents: 4 mm <sup>2</sup> multi-stranded Others: 2.5 mm <sup>2</sup> multi-stranded Display: 9-pin SUB-D female Service port: 9-pin SUB-D male
Response times	Response times are measured from end of period of measured current cycle Differential current: <50 ms
Protection	Case: IP40 Terminals: IP20 Operator panel (option): IP40 (IP54 when mounted with gasket) To IEC 529 and EM 60529
Mounting	Base-mounted with six screws or DIN-rail mounted
Weight	Approx. 1 kg incl. packing

### 3. Standard functions

#### 3.1 Differential current detection

The MDR-2 is primarily intended for protection of a generator or an electric motor against current leaks. This is accomplished by measuring the current on each side of the generator/motor and comparing these. If there is a difference (differential current), a leak is detected.

The differential current detection takes place in each phase.

So, the differential current detection is based on:

Primary side		Secondary side
(I1)		(I2)
L1	compared to	L1
L2	compared to	L2
L3	compared to	L3

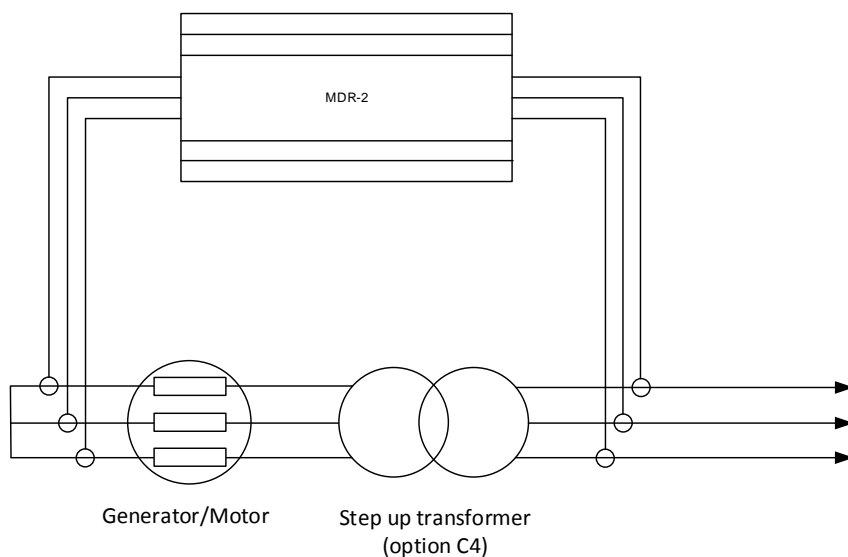

### 3.1.1 Differential current tripping/warning

The pickup characteristics are defined using customisable curves.

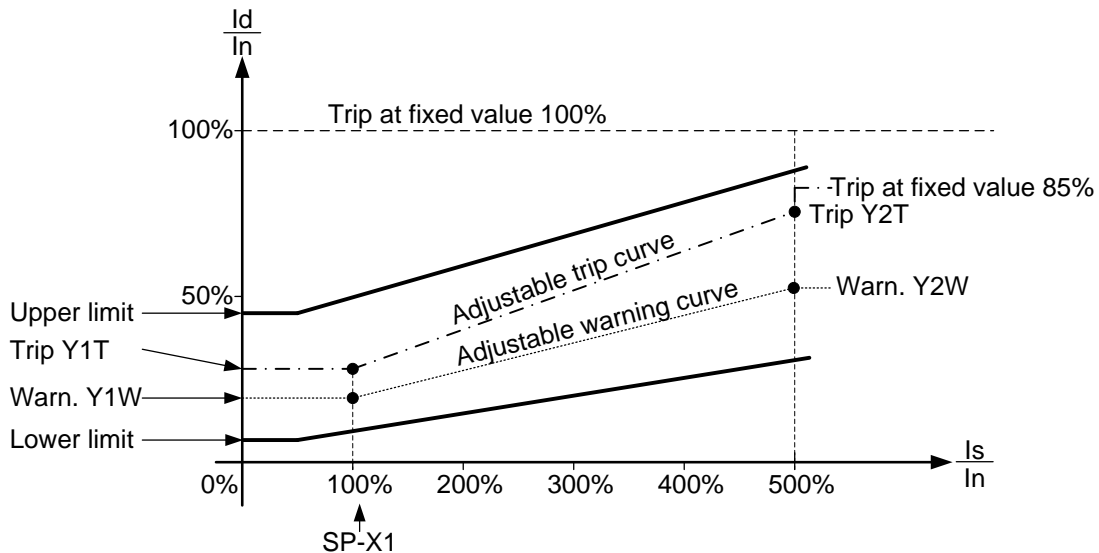

The trip/warning pickup characteristics are shown above. They are a function of:

- Stabilisation current  $I_s$  in relation to nominal current  $I_n$  (X-axis)
- Differential current  $I_d$  in relation to nominal current  $I_n$  (Y-axis)

The lines marked "UPPER LIMIT" and "LOWER LIMIT" are the limits for the curves.

Max. values are:

- X1: 500 %
- Y1: 45 %
- Y2: 95 %

Min. values are:

- X1: 50 %
- Y1: 5 %
- Y2: 25 %

There are two sets of adjustable settings:

- Warning, set points Y1W and Y2W (can be disabled)
- Trip, set points SP-X1, Y1T and Y2T

The warning curve shares the SP-X1 value with the trip curve.

Both settings are with adjustable time delay (0.01 to 2.00 sec.)

## 3.2 Display

Front-mounted display with push-buttons and display of all measured values and alarms.

The following values can be read:



- Phase currents L1, L2, L3 primary side (I1)
- Phase currents L1, L2, L3 secondary side (I2)
- Phase currents are presented in actual current and % of nominal value
- Differential currents are presented in actual current and % of nominal value
- Stabilisation currents (average of I1 and I2 values, displayed for each phase)

The alarm and event log list can be read.

All parameter settings can be made via the display.

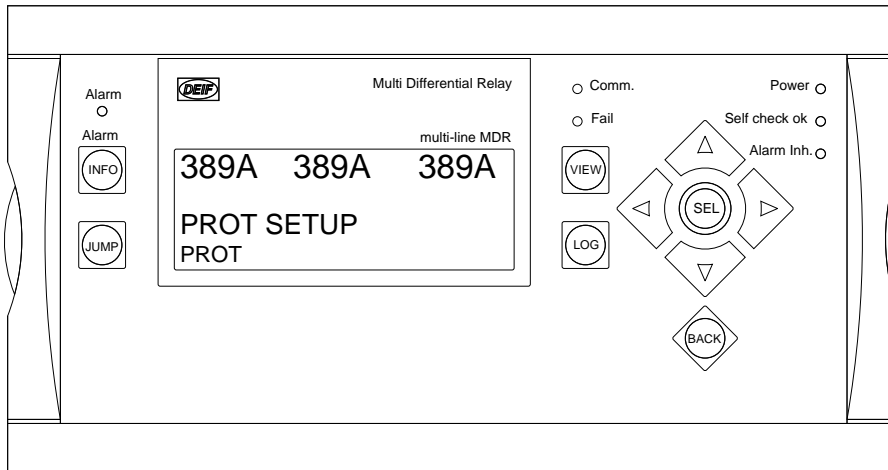

The push-buttons are:

- INFO:** Displays the alarm list. If no active alarms are present, the list will be empty.
- JUMP:** Enables the user to jump directly to a specific setting instead of entering via the menu system.
- VIEW:** Scrolls the readings in the upper line of the display (in the protection setting menu).
- LOG:** Enters the log list. The log list contains max. 150 historical events/alarms, all with time and date.
- SEL:** Selects the chosen menu/value (enter function).

 Up/down value buttons. Used for changing of settings, and so on.

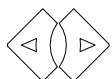
 Move buttons. Moves the cursor (in the lower line of the display) during manoeuvring in the menu.

### 3.2.1 Panel cutout for display

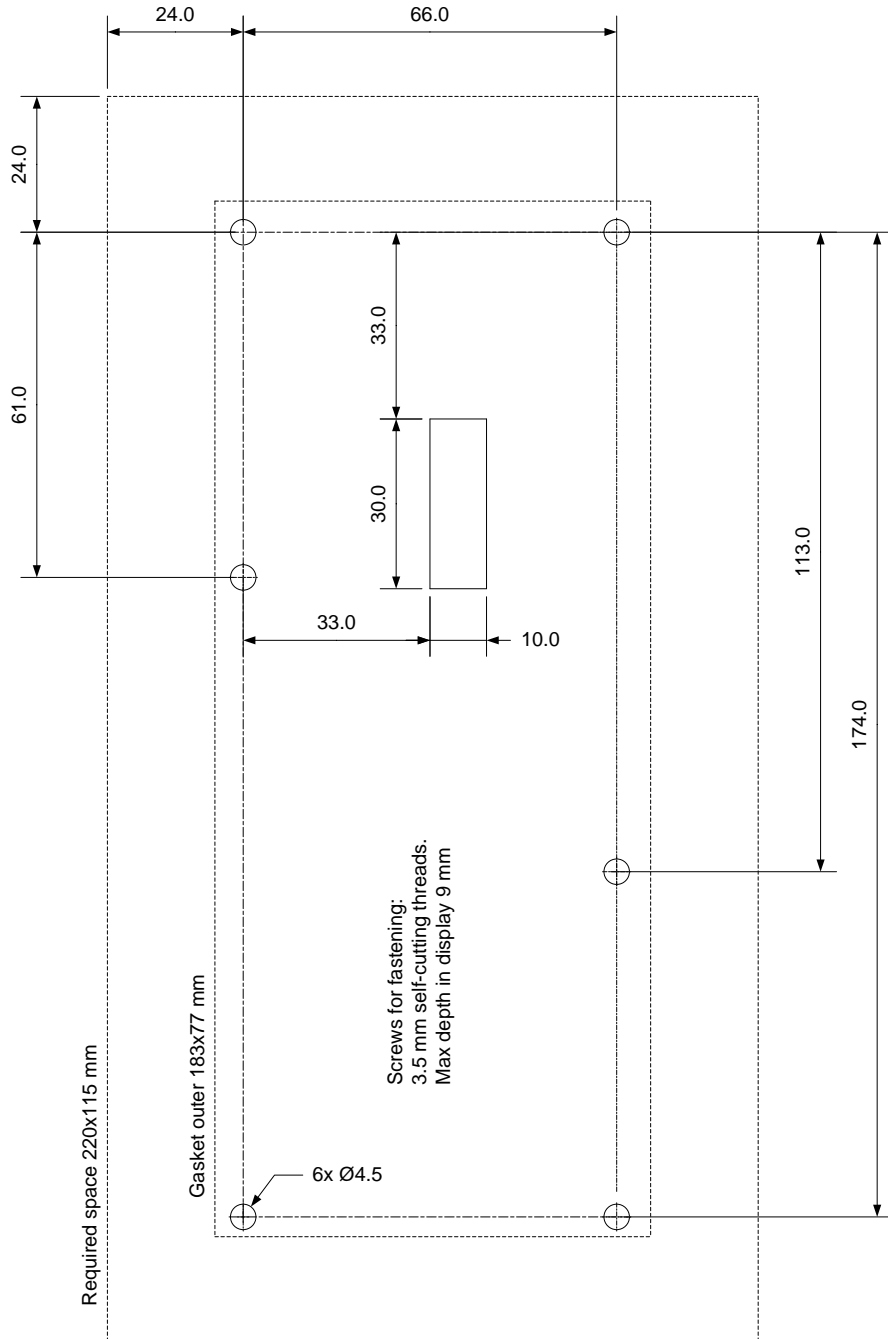

### 3.2.2 Unit dimensions in mm (inches)

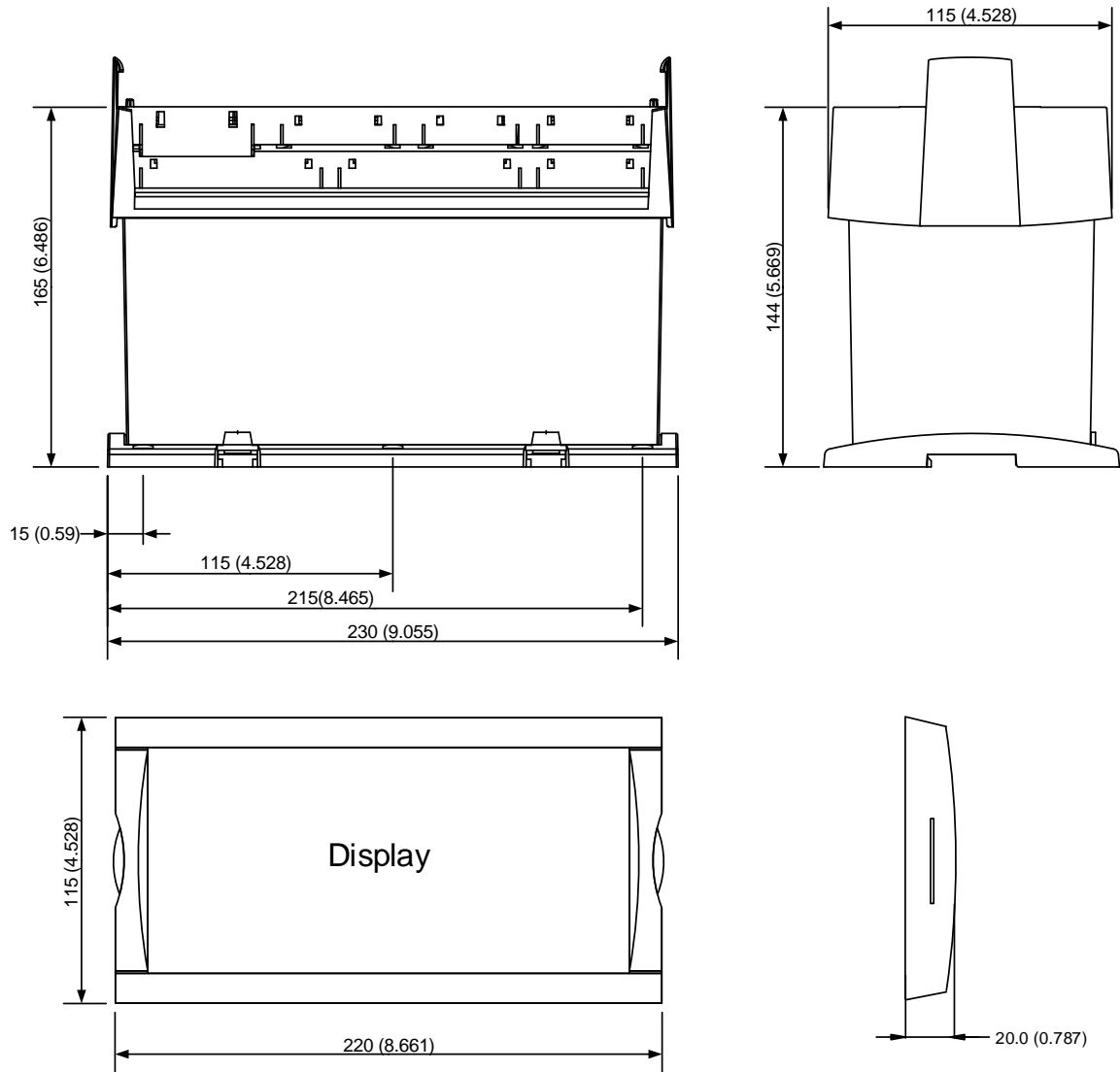

## 4. Hardware

### 4.1 Terminals and board slot positions

The Multi-line 2 housing is divided into board slot positions, some of which are standard (non-changeable) and some intended for options. The MDR-2 unit is divided like this:

Slot	Slot type	Terminal	MDR-2
Slot #1	Power supply and digital I/O	1-28	Standard
Slot #2	Not used	29-36	
Slot #3	Not used	37-64	
Slot #4	Not used	65-72	
Slot #5	Not used	84-89	
Slot #6	Not used	90-97	
Slot #7	AC current measurement	98-109	Standard
Slot #8	Not used	126-133	

An overview of the terminals can be seen below. The slots are positioned in the unit as follows (seen from the top of the unit):

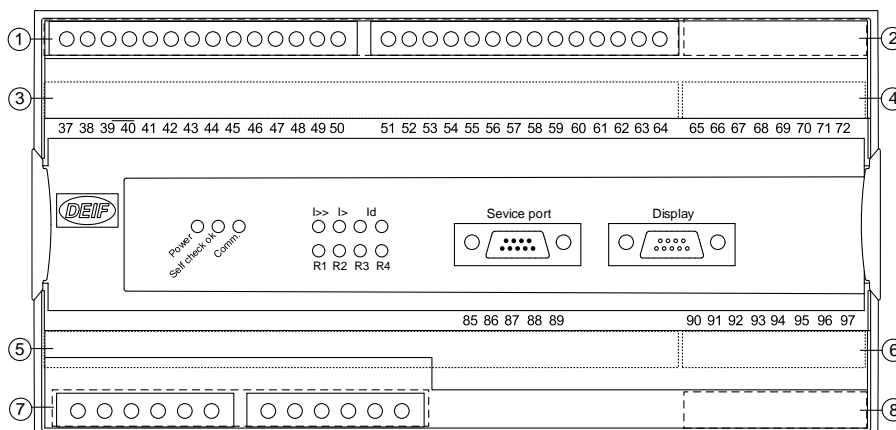

### 4.2 Base unit LED indicators

There are 11 LED indicators on the front of the base unit. The indications are:

- Power: DC power is on
- Self check OK: The microprocessor watchdog status is OK. This relates to the "Status" relay output (normally energised)
- Comm.: Communication status: not used
- >>: Option: short-circuit trip indication
- >: Option: over-current trip indication

Id:                    There are two LEDs. The left one is differential current warning, the right one is differential current trip

R1, R2, R3, R4:    Green by deactivated relay output, red by activated relay output

**NOTE:**

I>> and I> share the same LEDs.

I>>, I> and Id LEDs are turned off if the function is not chosen or inhibited.

I>>, I> and Id LEDs can indicate status (yellow light) if the function is turned ON. Refer to the paragraph "Status LED".

### 4.3 Terminal strip overview

#### 4.3.1 Slots #1, #2, #5 and #6

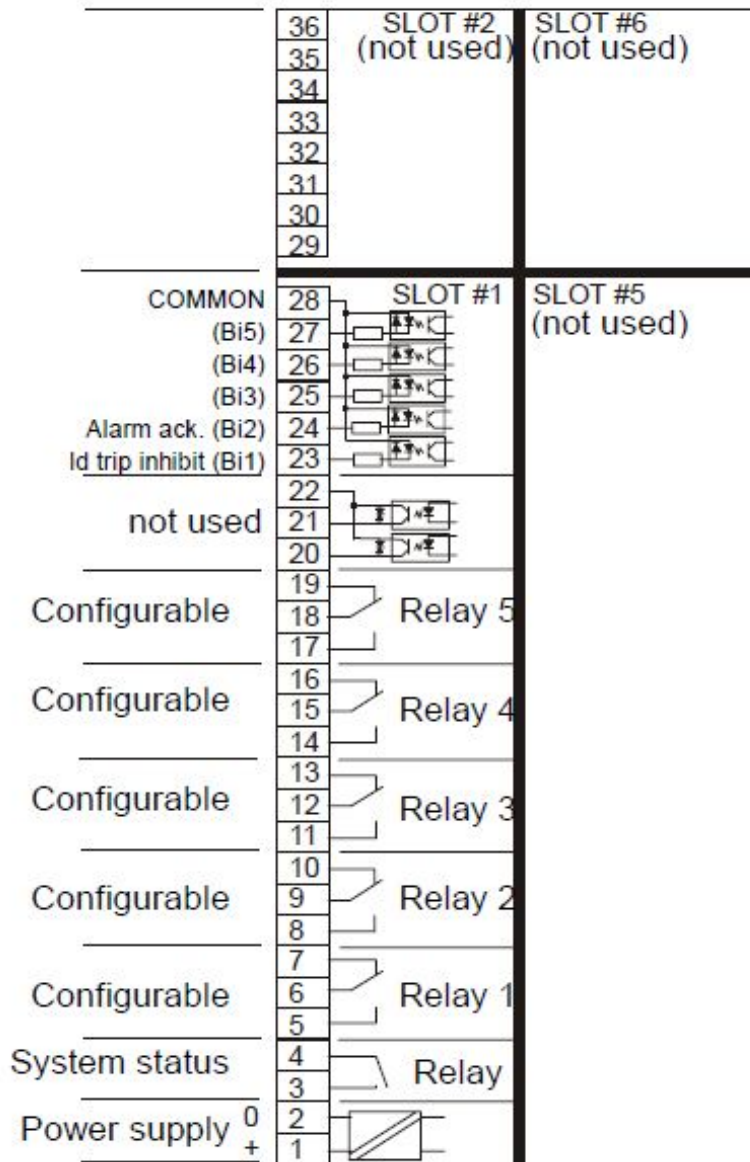

### 4.3.2 Slots #3, #4, #7 and #8

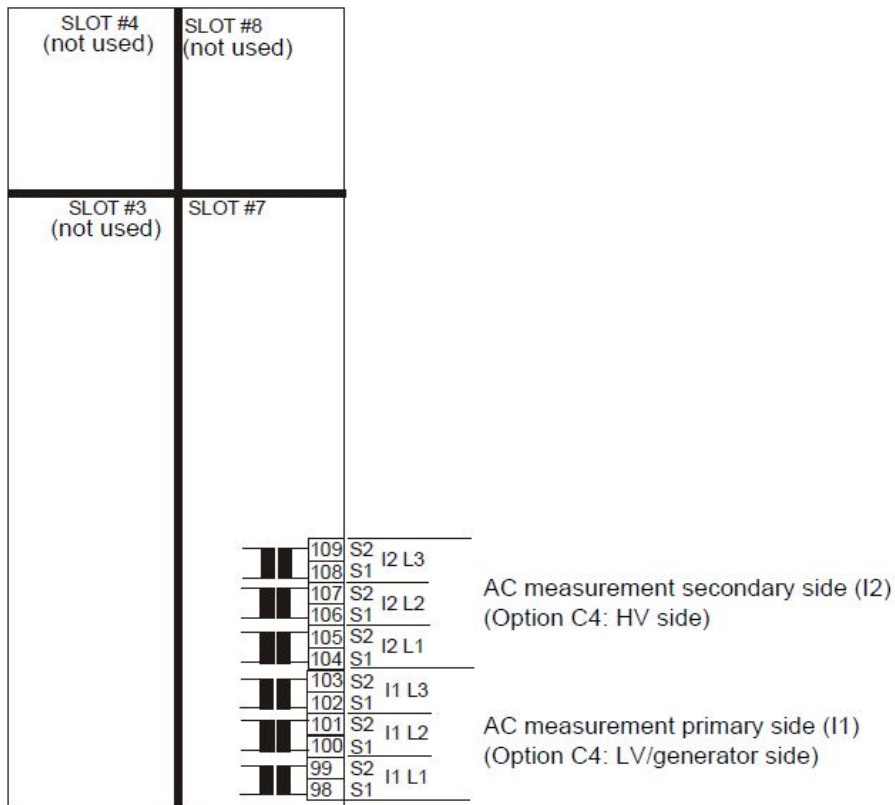

## 4.4 Terminal strip, explanation

For the relay outputs, the following terms will be used:  
 NO means Normally Open  
 NC means Normally Closed  
 Com. means common terminal for the relay in question

#### 4.4.1 Slot #1, power supply and digital I/O

Standard board (always needed)

Terminal	Function	Technical data	Description
1	+24 V DC	24 V DC +20/-30 %	Power supply
2	0 V DC		
3	NC	Status relay 24 V DC/1 A	Normally closed relay, processor/power supply status supervision
4	Com.		
5	NO	Relay 1 250 V AC/8 A	Configurable relay
6	Com.		
7	NC		
8	NO	Relay 2 250 V AC/8 A	Configurable relay
9	Com.		
10	NC		
11	NO	Relay 3 250 V AC/8 A	Configurable relay
12	Com.		
13	NC		
14	NO	Relay 4 250 V AC/8 A	Configurable relay
15	Com.		
16	NC		
17	NO	Relay 5 250 V AC/8 A	Configurable relay
18	Com.		
19	NC		
20		Not used	
21			
22			
23	Digital input 1	Optocoupler	Id trip inhibit (differential current trip inhibit)
24	Digital input 2	Optocoupler	Alarm acknowledge
25	Digital input 3	Optocoupler	
26	Digital input 4	Optocoupler	
27	Digital input 5	Optocoupler	
28	Com.	Common	Common for terminals 23 to 27



#### 4.4.2 Slot #7, AC current measurement

Terminal	Function	Technical data	Description
98	S1 (k)	I 1L1	Primary side current measurements (I1)
99	S2 (l)		
100	S1 (k)	I 1L2	
101	S2 (l)		
102	S1 (k)	I 1L3	
103	S2 (l)		
104	S1 (k)	I 2L1	Secondary side current measurements (I2)
105	S2 (l)		
106	S1 (k)	I 2L2	
107	S2 (l)		
108	S1 (k)	I 2L3	
109	S2 (l)		

## 5. Wiring diagrams

### 5.1 Coupling and connection

#### 5.1.1 AC current measurements, star coupling

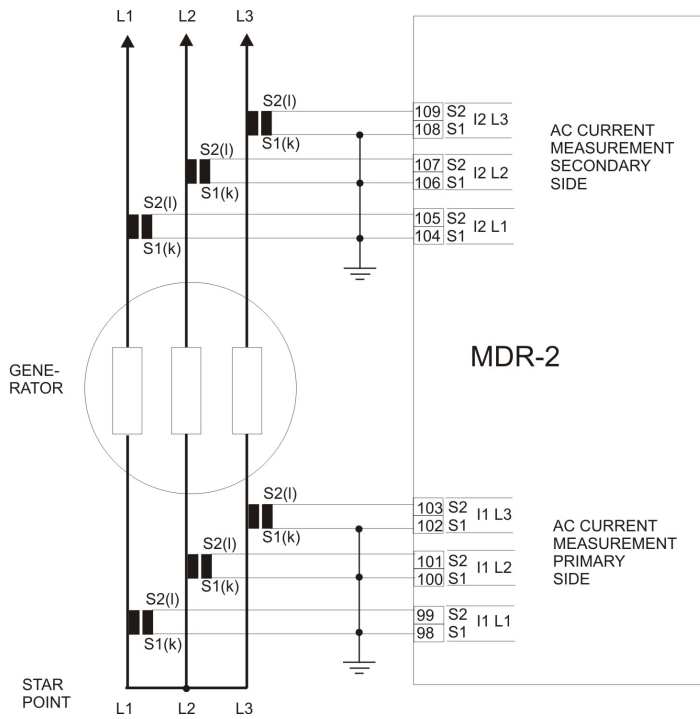

The ground connections can be connected to S1 or S2 as needed.

### 5.1.2 AC current measurements, delta coupling

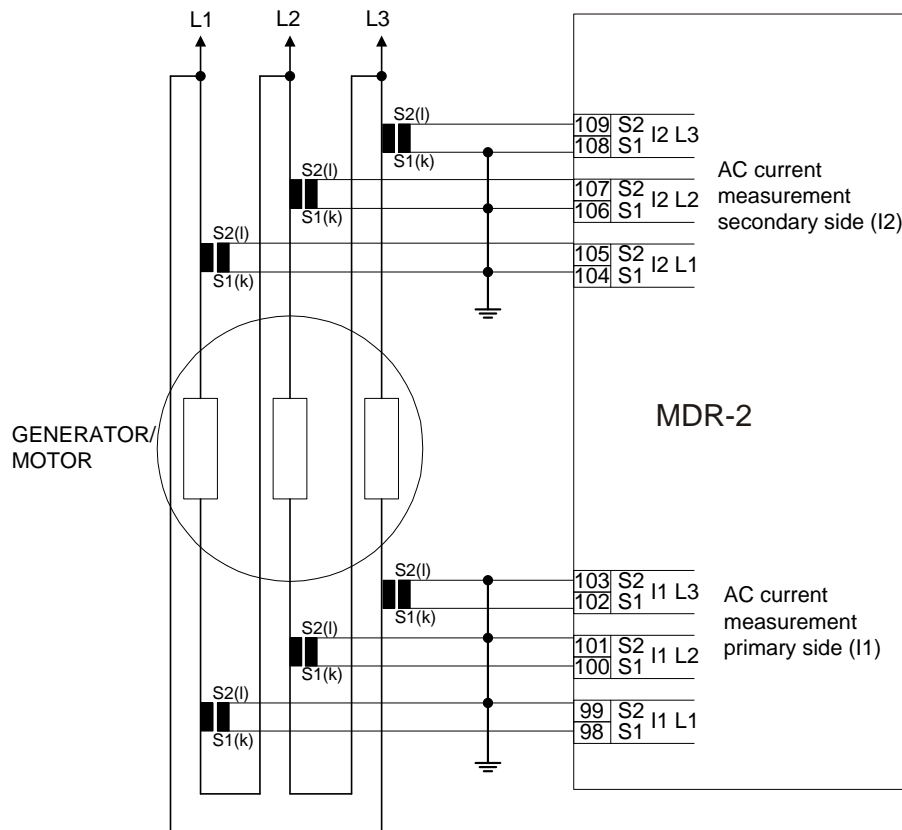

The nominal current setting is to be the name plate current divided by  $\sqrt{3}$ .



The ground connections can be connected to S1 or S2 as needed.

### 5.1.3 DC connections, inputs and outputs

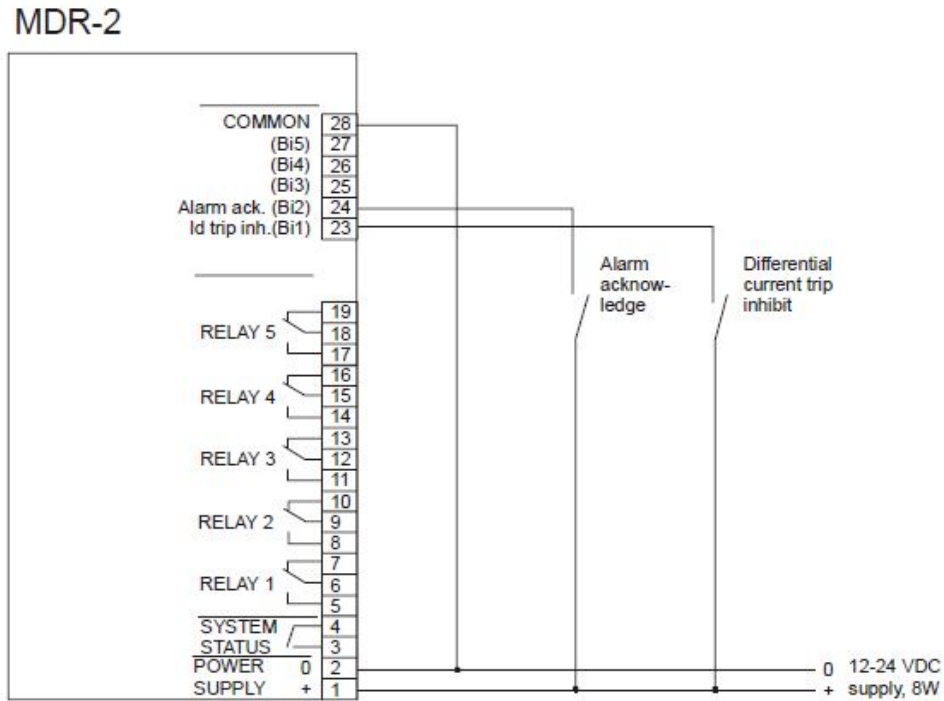

Alarms can be acknowledged by:



- 1) Using the display
- 2) Activating the alarm acknowledge input
- 3) Auto acknowledge. The use of this is selected in the setup menus.

## 6. Parameter programming

### 6.1 Programming

#### 6.1.1 About programming

All settings can be programmed using the DEIF utility software for Multi-line 2 or via the display. All parameters are protected by a password.

In the following, the term "No." (number) refers to a specific number used for each setting. The first digit in the number indicates which group the setting belongs to.

#### 6.1.2 Parameter setting method in display

The parameter setting menu is chosen by placing the cursor (underscore) under "PROT" (move the cursor with the buttons) in the lower line of the display and pressing "SEL".



The following display appears:

Is	0	0	0%
1010 Diff. Current W			
Setpoint	20.0%		
<u>Y1W</u>	Y2W	DEL	OA OB EN

As it can be seen, the cursor is placed under "Y1W".

If "SEL" is pressed, the setting of set point Y1W is entered (password-protected):

Is	0	0	0%
1011 Diff. Current W			
5.0...	20.0...	45.0%	
<u>RESET</u>	SAVE		

The value can now be changed with the  and  buttons.

When a value is to be stored, remember to move the cursor to "SAVE" and then press "SEL".

Explanations for the different possible settings are made in the next paragraphs.



In these displays, the "VIEW" button can be used to change the upper line reading.

## 6.2 Differential current

### 6.2.1 Settings

The setting of differential current warning/trip is done by using five set points:

- Common for trip and warning is SP-X1 (placed under trip (curve 2) setting)

- Warning Y1W and Y2W
- Trip Y1T and Y2T

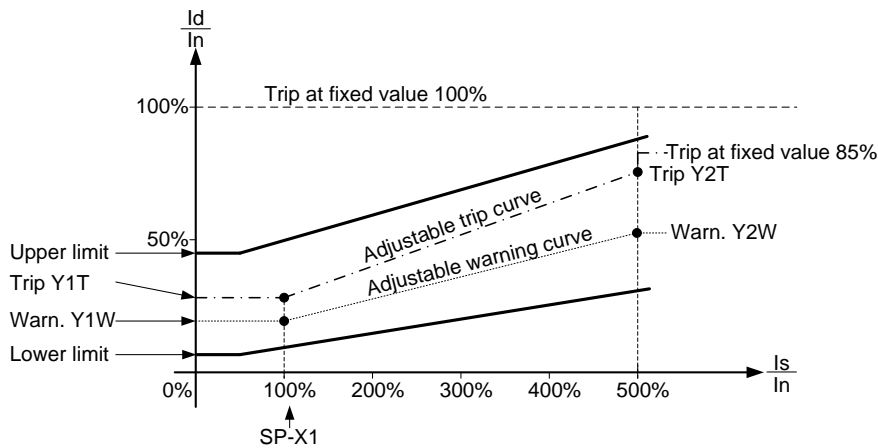

### 6.2.2 Warning (curve 1)

No.	Setting		Min. setting	Max. setting	Factory setting
1010	Diff. current warning	Selection display	-	-	-
1011	Diff. current warning	SP-Y value 1 warning, Y1W	5 %	45 %	20 %
1012	Diff. current warning	SP-Y value 2 warning, Y2W	25 %	95 %	55 %
1013	Diff. current warning	Delay	0.01 s	2.00 s	0.10 s
1014	Diff. current warning	Relay output A	R0 (none)	R5 (relay 5)	R3 (relay 3)
1015	Diff. current warning	Relay output B	R0 (none)	R5 (relay 5)	R5 (relay 5)
1016	Diff. current warning	Enable	OFF	ON	ON

### 6.2.3 Trip (curve 2)

No.	Setting		Min. setting	Max. setting	Factory setting
1020	Diff. current trip	Selection display	-	-	-
1021	Diff. current trip	SP-X value 1 warn/trip, X1	50 %	300 %	100 %
1022	Diff. current trip	SP-Y value 1 trip, Y1T	5 %	45 %	25 %
1023	Diff. current trip	SP-Y value 2 trip, Y2T	25 %	95 %	70 %
1024	Diff. current trip	Delay	0.01 s	2.00 s	0.10 s
1025	Diff. current trip	Relay output A	R0 (none)	R5 (relay 5)	R4 (relay 4)
1026	Diff. current trip	Relay output B	R0 (none)	R5 (relay 5)	R5 (relay 5)

### 6.2.4 Trip (fixed trip value)

The fixed trip value refers to tripping when the differential current is 100 % or more.

No.	Setting		Min. setting	Max. setting	Factory setting
1030	Diff. fixed limit trip	Selection display	-	-	-
1031	Diff. fixed limit trip	Delay	0.01 s	2.00 s	0.05 s

The relays (max. two) to be activated are chosen under Trip (curve 2).

### 6.2.5 Use of relay outputs

For each function (warning and trip), two relay outputs can be set (relay output A and B). For both of these, any of the relays available (standard: relay 1-5) can be used.

Due to the fact that tripping the generator breaker is insufficient in case of a differential current failure, a total generator shutdown must be carried out. Dependent on the AVR (Automatic Voltage Regulator) in question, the AVR should also be tripped, ensuring that the generator voltage is removed immediately. It is suggested to use for example relay output A to trip the breaker and relay output B to trip the AVR. Alternatively, if that is not possible, to shut down the engine.

The reason for this shutdown is to stop the damaging current flow caused by the internal failure (differential current).

If warning or trip messages are to be sent to an alarm system, it is suggested to use separate relays for each warning or trip alarm sent to the alarm system. This enables the alarm system to identify the cause of alarm.

## 6.3 Other settings

### 6.3.1 Status LED

This setting enables/disables the use of yellow light in the protection LEDs. When set ON, the LEDs for I>>, I> and Id will indicate an alarm status (yellow), if the alarm set point is exceeded, but the delay timer is still running. If the timer has run out (the alarm is triggered), the LED will be red.

No.	Setting		First setting	Second setting	Factory setting
4300	Status info via LED	Selection display	-	-	-
4301	Status info via LED	Show status	OFF	ON	OFF

### 6.3.2 Auto acknowledgement of alarms

Automatic acknowledgement of alarms is activated by turning setting 4312 ON.

No.	Setting		Min. setting	Max. setting	Factory setting
4310	Auto acknowledge	Selection display	-	-	-
4311	Auto acknowledge	Delay	0.10 s	10.00 s	2.00 s
4312	Auto acknowledge	Enable	OFF	ON	OFF

### 6.3.3 Service menu

The service menu can only be entered using the "JUMP" push button. In this menu, status and timers can be seen (useful in commissioning situations).

No.	Setting		Min. setting
4980	Service menu	Selection display	-
4981	Service menu	Alarm	Shows remaining delay time
4982	Service menu	Digital input	Shows digital input status
4983	Service menu	Relay output	Shows relay output status

## 6.4 Nominal settings

### 6.4.1 Nominal current

The nominal current is the nominal current of the generator.

No.	Setting		Min. setting	Max. setting	Factory setting
4010	Nominal settings	Selection display	-	-	-
4011	Nominal settings	Nominal frequency	48 Hz	62 Hz	50 Hz
4012	Nominal settings	Nominal current	1 A	10000 A	787 A

**i** If the generator/motor is delta-coupled, the nominal current setting is to be the name plate current divided by  $\sqrt{3}$ .

### 6.4.2 Current transformers

The six current transformers are to be placed like this:

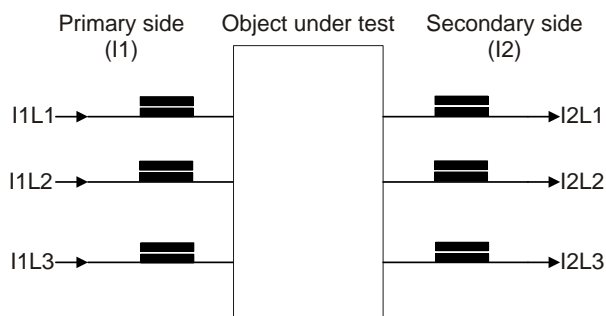

The object under test can be:

- A generator
- An electric motor

Transformer ratio for current measurements I1L1, I1L2, I1L3, I2 L1, I2L2 and I2L3.



No.	Setting		Min. setting	Max. setting	Factory setting
4020	Trafo ratio	Selection display	-	-	-
4021	Trafo ratio	Current prim.	5 A	10000 A	1000 A
4022	Trafo ratio	Current sec.	1 A	5 A	1 A

### 6.4.3 Date and time (internal clock)

No.	Setting		Min. setting	Max. setting	Factory setting
4100	Date and time	Selection display	-	-	-
4101	Date and time	Year	Factory setting is random. Time and date must be set during commissioning.		
4102	Date and time	Month			
4103	Date and time	Date			
4104	Date and time	Hour			
4105	Date and time	Minute			

### 6.4.4 Power supply (battery) under-voltage alarm

No.	Setting		Min. setting	Max. setting	Factory setting
4220	Battery low V	Selection display	-	-	-
4221	Battery low V	Set point	8.0 V	24.0 V	18.0 V
4222	Battery low V	Time	0.00 s	10.00 s	1.00 s
4223	Battery low V	Relay output A	R0 (none)	R5 (relay 5)	R0 (none)
4224	Battery low V	Relay output B	R0 (none)	R5 (relay 5)	R0 (none)
4225	Battery low V	Enable	OFF	ON	ON

### 6.4.5 User password for programming via display

The user password can only be entered using the "JUMP" push-button on the display.

No.	Setting		Min. setting	Max. setting	Factory setting
4971	User password	Setting	0	32000	2000

### 6.4.6 Language selection

No.	Setting		Setting	Factory setting
4230	Language	Selection display	-	-
4231	Language	English	0	1
		Deutsch	1	-
		Français	2	-
		Español	3	-