

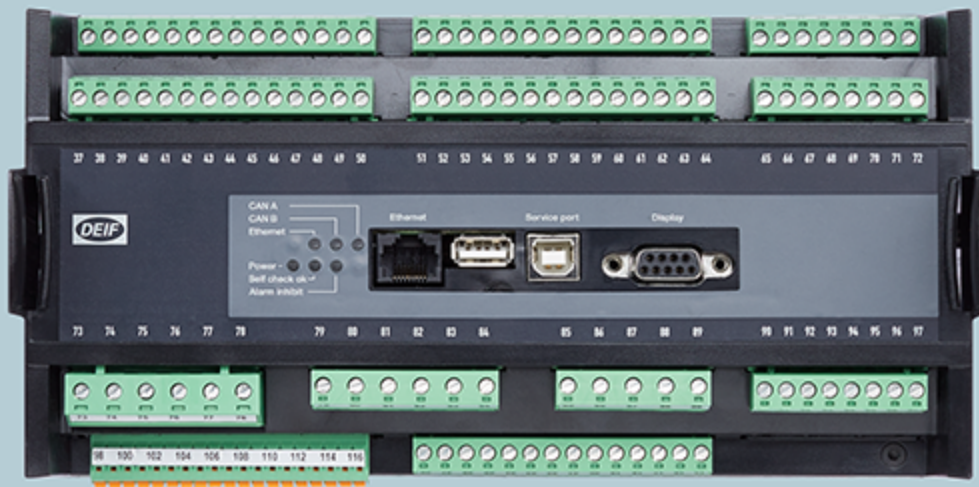

DATA SHEET



AGC-4



1. Overview

1.1 AGC-4	4
1.2 Single-line application diagrams	5
1.2.1 Single genset.....	5
1.2.2 Power management.....	7
1.2.3 Extended power management.....	11
1.3 General functions	12
1.3.1 Functions.....	12
1.3.2 Protections.....	13
1.3.3 Application emulation.....	15
1.4 Power management	15
1.4.1 Safe power management.....	15
1.4.2 Applications.....	15
1.4.3 Plant modes.....	16
1.4.4 Power management functions.....	16
1.4.5 Easy configuration of single-line diagrams.....	16
1.5 Hardware	17
1.5.1 Inputs and outputs.....	17
1.5.2 Terminal overview.....	17

2. Optional hardware

2.1 AGC-4 hardware options	19
2.1.1 Hardware options and slot numbers.....	19
2.1.2 Variants.....	21
2.1.3 Accessories.....	21
2.2 TDU 107 touch display unit	22
2.2.1 Overall description.....	22
2.3 DU-2 display unit	22
2.3.1 Option Y1 (Island engine and GB control).....	23
2.3.2 Option Y3 (Engine, GB and MB control).....	23
2.3.3 Option Y4 (TB and MB control).....	23
2.3.4 Option Y5 (Bus tie breaker control).....	23
2.3.5 Option Y8 (Group control).....	23
2.3.6 Option Y9 (Plant control).....	24
2.3.7 Option X3 (AOP-1).....	24
2.3.8 Option X4 (AOP-2).....	24

3. Optional software

3.1 Software options	25
-----------------------------------	-----------

4. Compatible products

4.1 Touch display unit: TDU 107	27
4.2 Remote monitoring service: Insight	27
4.3 Digital voltage controller: DVC 550	27
4.4 Additional inputs and outputs: CIO 116, 208 and 308	27
4.5 Other controllers	27
4.6 Remote maintenance box (RMB)	27
4.7 Other equipment	27

5. Technical information

5.1 Technical specifications.....	28
5.2 Dimensions.....	31

6. Ordering information

6.1 Order specifications.....	32
6.2 Disclaimer.....	32
6.3 Copyright.....	32

1. Overview

1.1 AGC-4

The AGC-4 is a configurable controller that can be used in applications ranging from a single controller for one genset, to complete power management systems. The controller contains the 3-phase measuring circuits and all the functions required to protect and control a genset. The controllers can also be used to protect and control mains connections, tie breakers, and bus tie breakers.

Up to 40 AGCs can be connected in a power management system. AGC-4 can also be combined with AGC 150 (up to 32), ASC-4 (Solar and/or Battery), and/or ALC-4 (Automatic Load Controller).

With extended power management, a system can manage up to 992 gensets (each controlled by AGC-4).

AGC-4 controller	Application type	Option	Breakers that can be controlled*
Genset	Single genset	-	GB only, or GB & MB
Genset	Power management	G5	GB only
Mains	Power management	G5	MB only, or MB & TB, or TB only
BTB	Power management	G5	BTB only
Group	Extended power management	G7	TB only
Plant	Extended power management	G7	MB only

*Note: GB = Generator breaker; MB = Mains breaker; TB = Tie breaker; BTB = Bus tie breaker.

Modes	Single genset	Power management
Island operation	Synchronising or a stand-alone genset. Can also be used in critical power applications.	Power plant with synchronising gensets or a stand-alone genset. Can also be used in critical power plants with a start signal from an external (ATS) controller.
Automatic Mains Failure	Emergency standby genset, black start genset.	Critical power, emergency standby plants, black start genset.
Fixed power	Genset with fixed kW set point (including building load).	Power plant with fixed kW set point (including building load).
Peak shaving	Genset supplies peak load demand paralleled to the mains.	Power plant where genset(s) supply peak load demand paralleled to the mains.
Load takeover	The load is moved from mains to genset, for example, peak demand periods or periods with risk of power outages.	The load is moved from mains to the genset(s), for example, peak demand periods or periods with risk of power outages.
Mains power export	Genset with fixed kW set point (excluding building load).	Power plant with fixed kW set point (excluding building load).
Remote maintenance	The genset has to supply the load while a distribution transformer needs to be disconnected for service. Remote maintenance requires a DEIF RMB box (separate product) and a set of cables (option J8).	Island power management, with up to 32 gensets. This requires a DEIF RMB box (separate product), a set of cables (option J8), and RMB with multiple gensets (option T4).

The plant modes are configurable, and it is possible to change the plant mode on the fly. All modes can be combined with Automatic Mains Failure mode (AMF).

Each controller can be controlled from the TDU 107 touch screen or the DU-2 LCD display. An HMI/SCADA system can be implemented using one of the communication options.

1.2 Single-line application diagrams

1.2.1 Single genset

Automatic mains failure and fixed power/base load

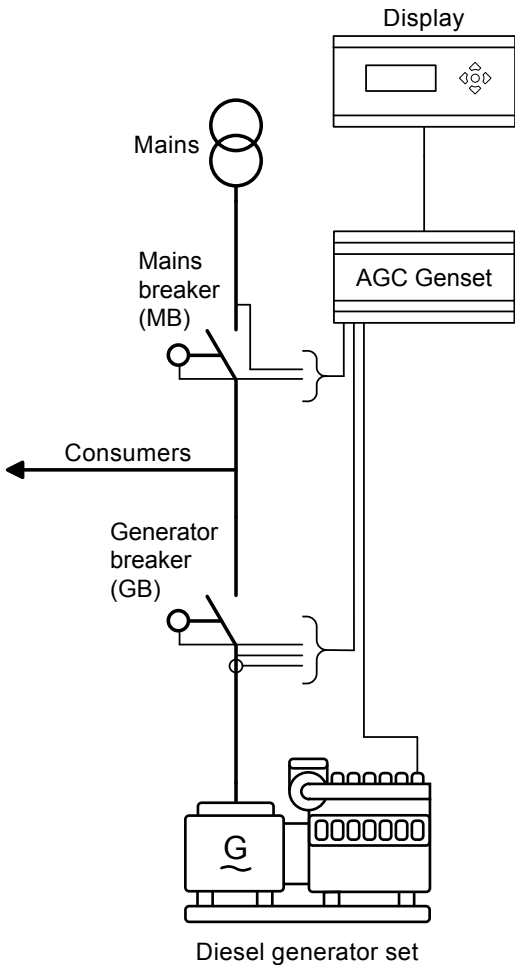

Island operation

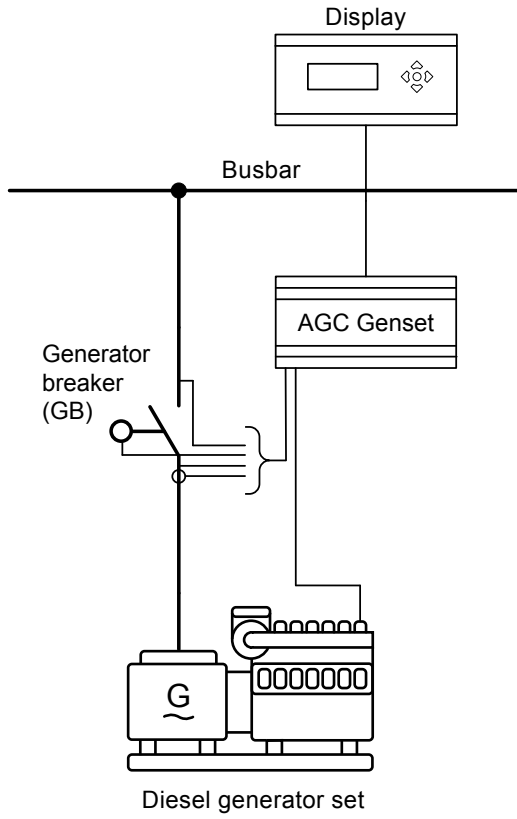

Peak shaving, load takeover and mains power export

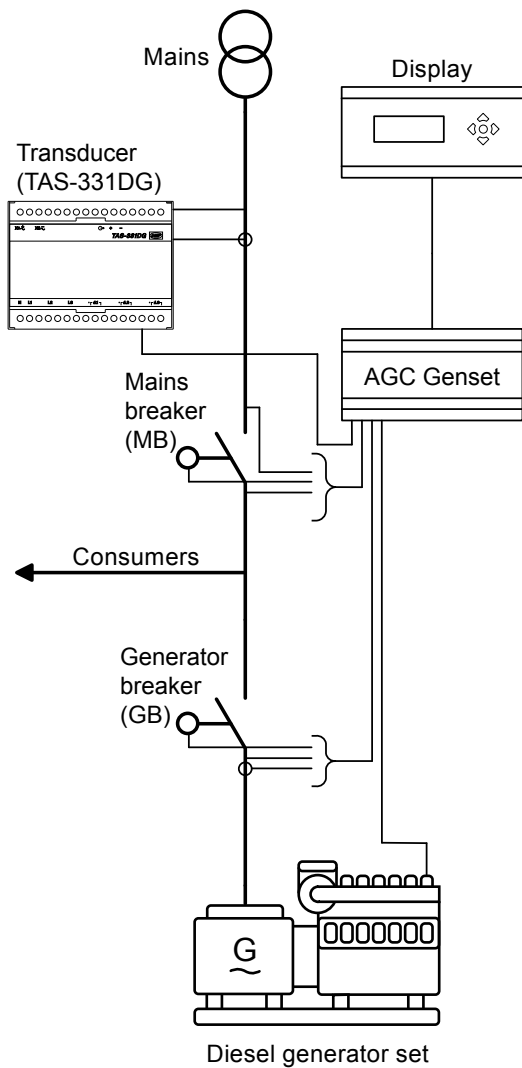

Multiple gensets, load sharing (1 controller per genset)

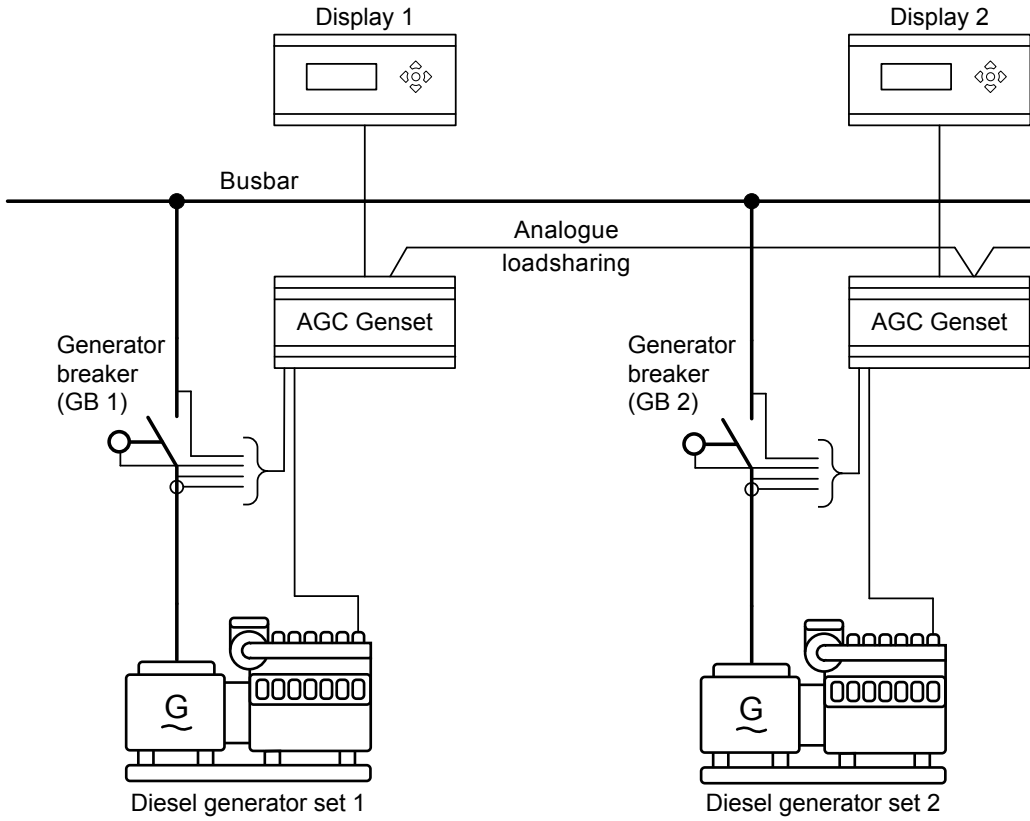

1.2.2 Power management

Island operation

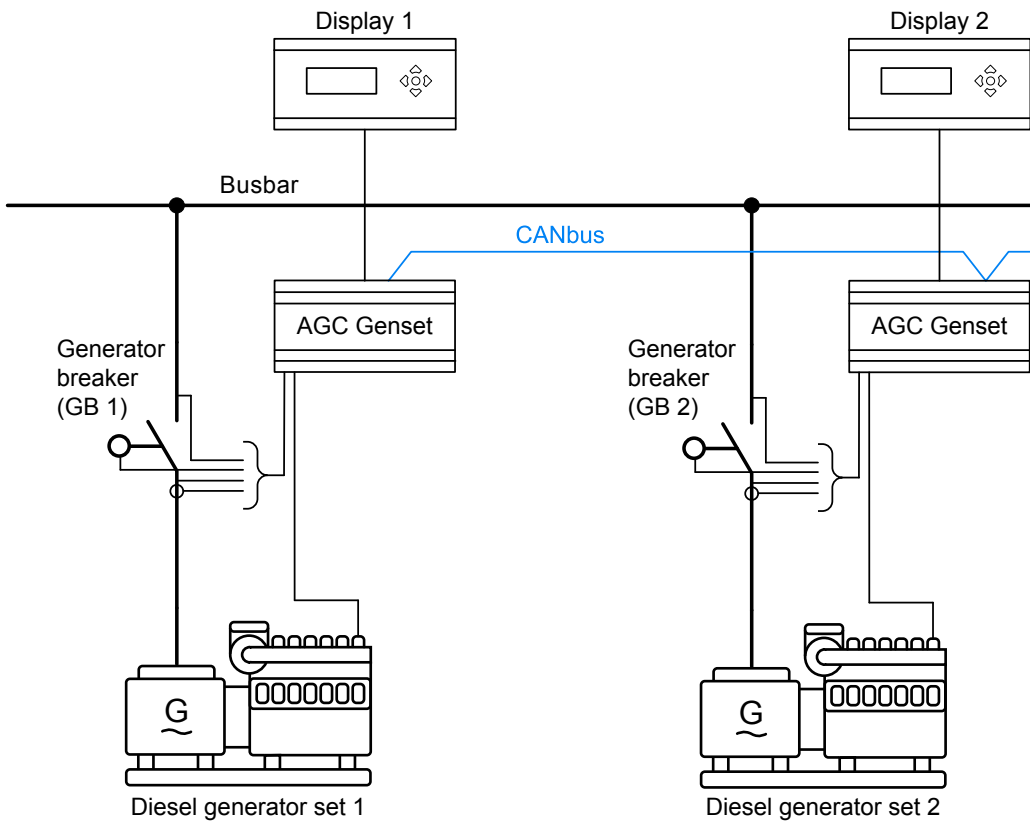

Parallel with mains

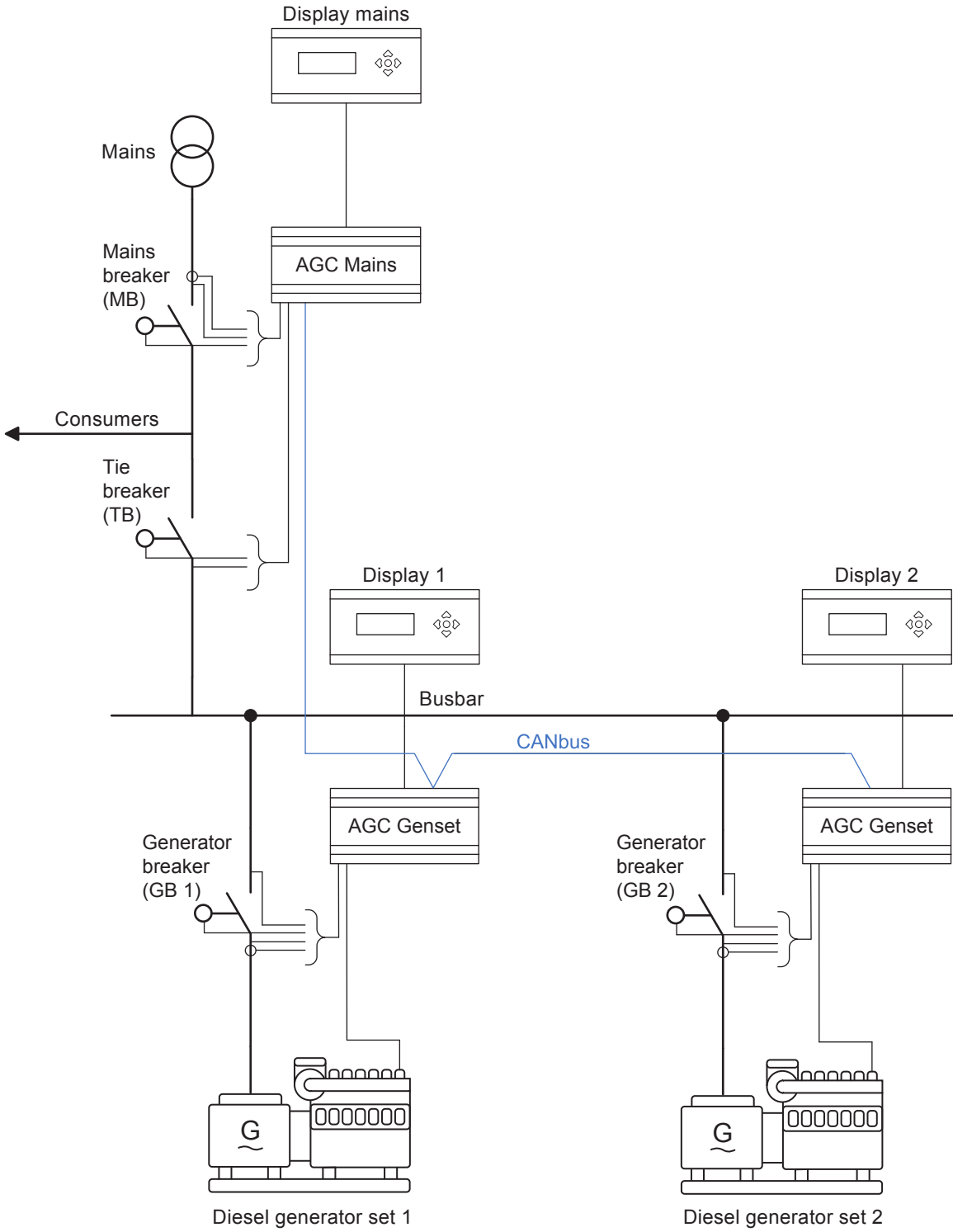

Main - tie - main application

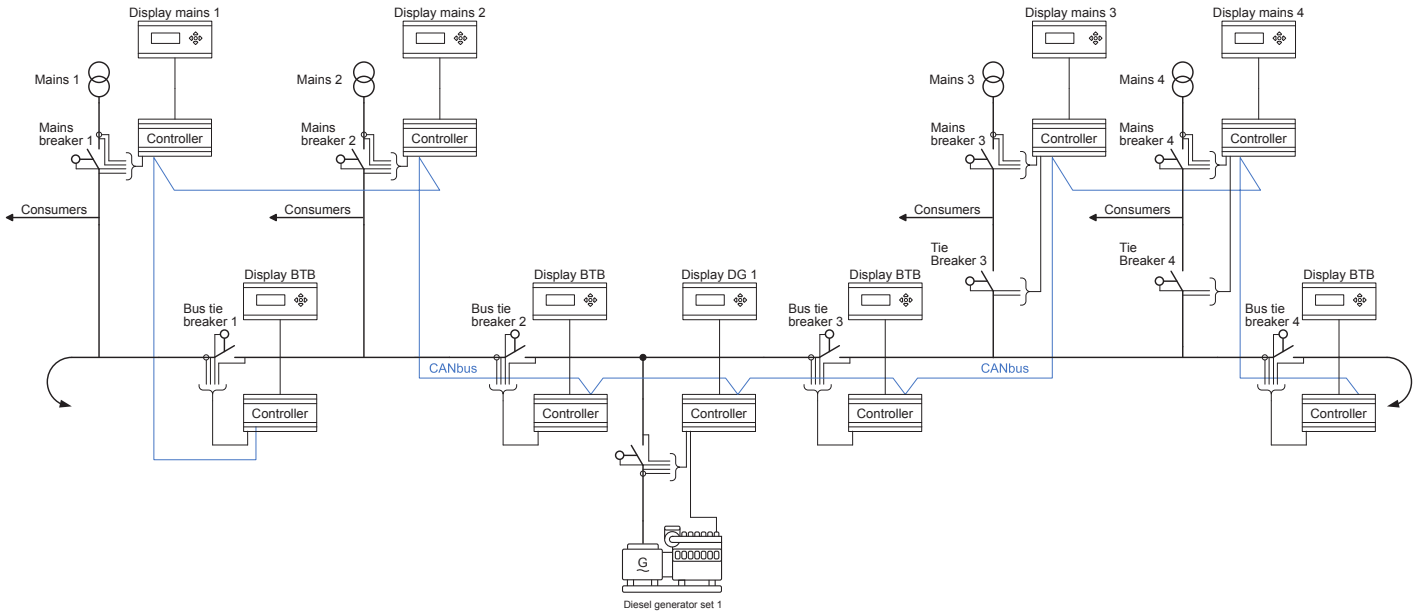

INFO

Power management with a ring busbar is possible.

H-coupling

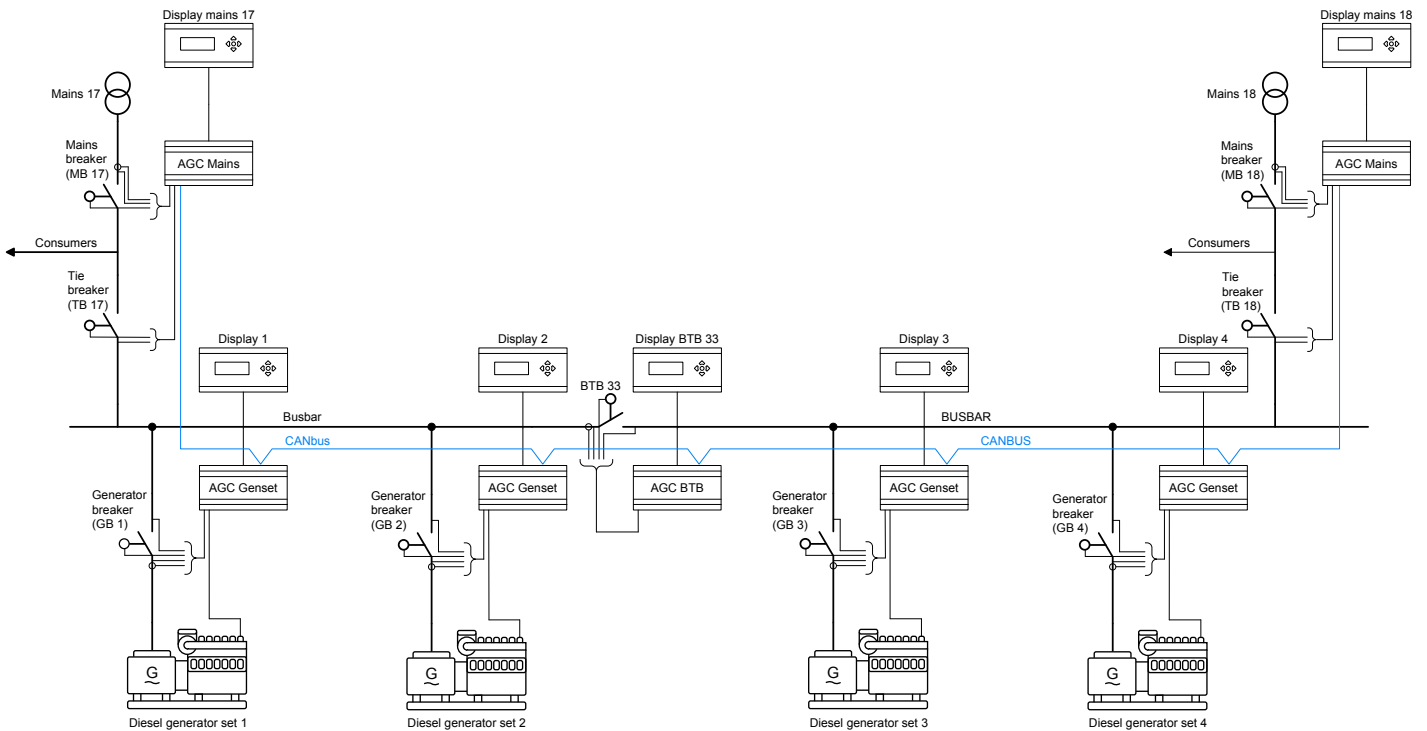

A bus tie breaker can be present without an AGC controller, however, the open and closed feedbacks must be connected to an AGC.

Multiple mains and one genset

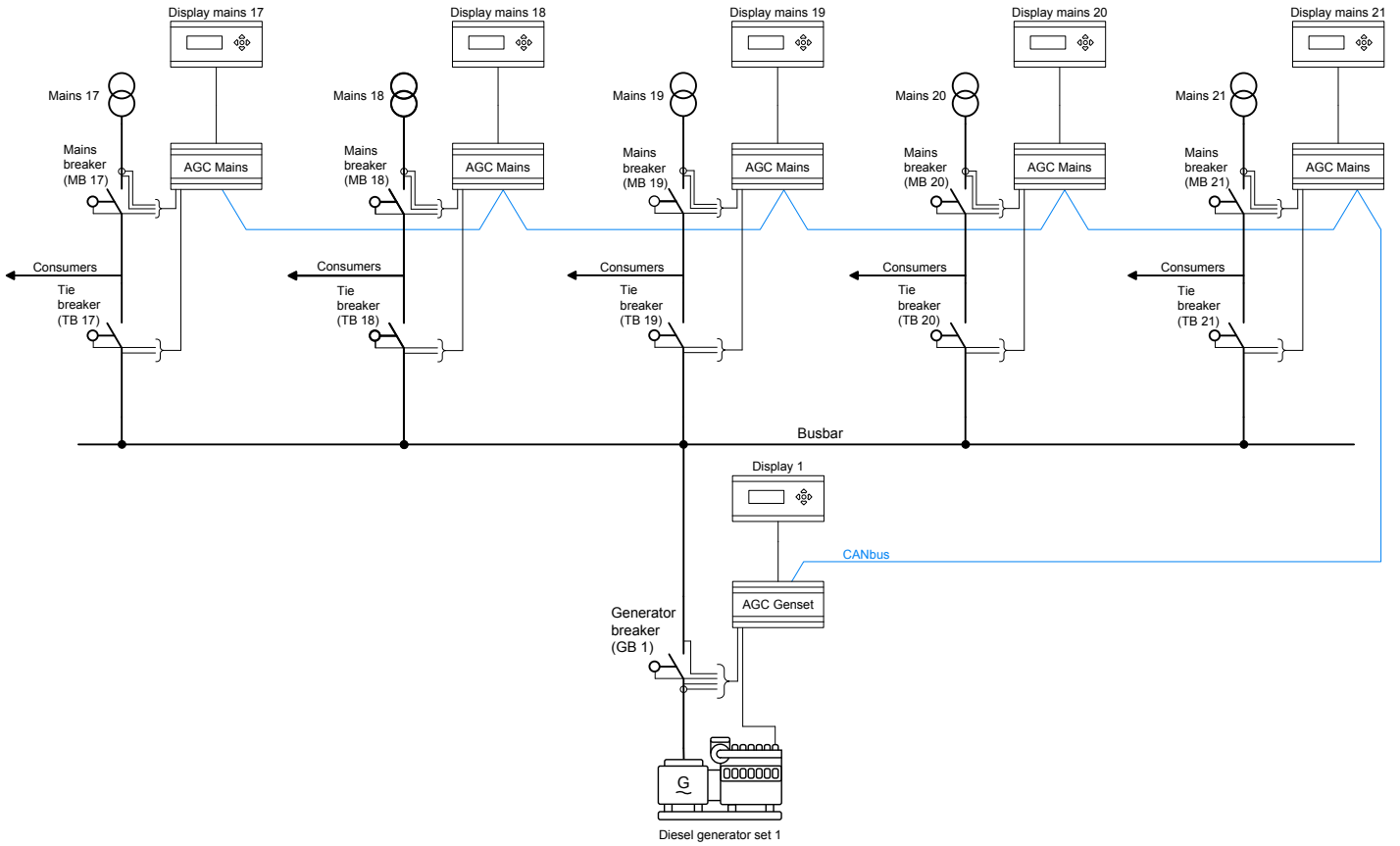

Hybrid power management system

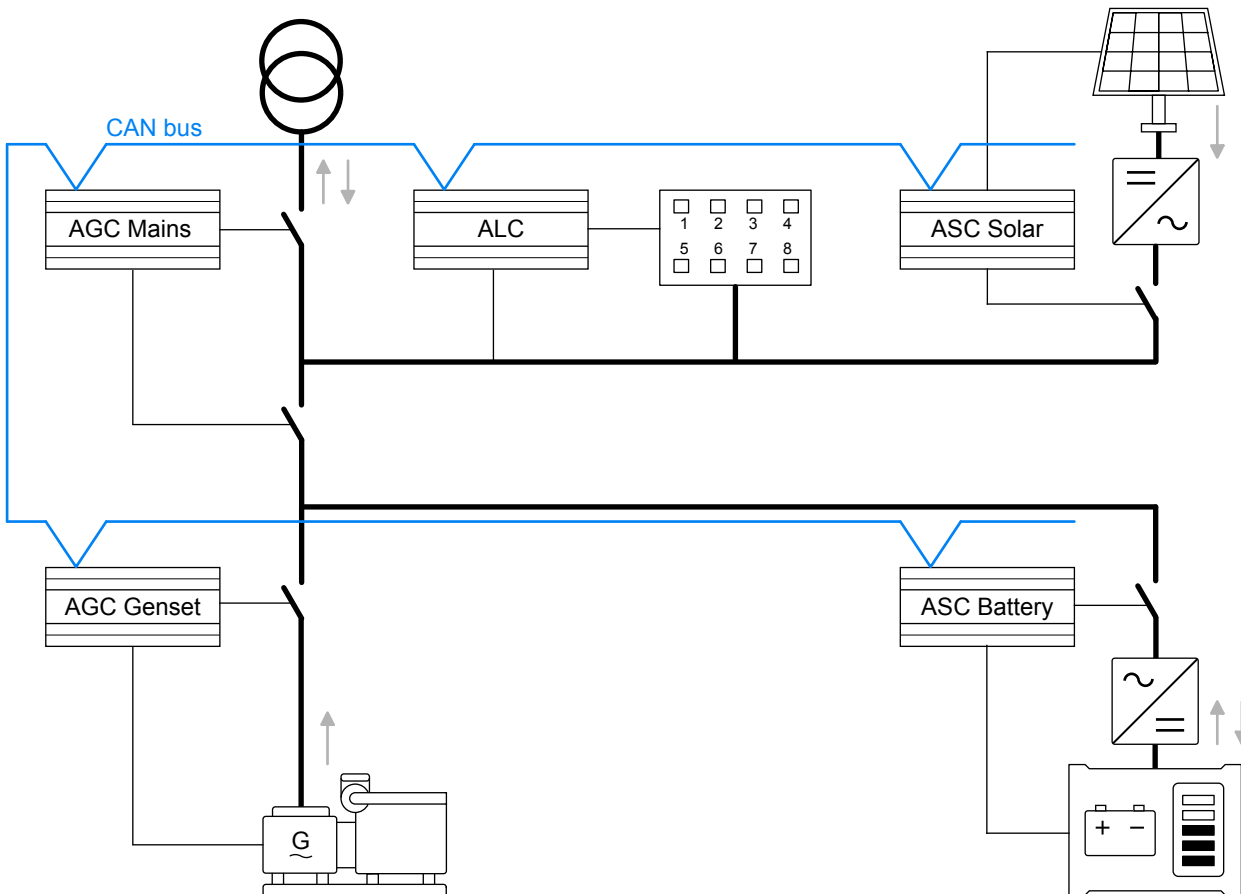

1.2.3 Extended power management

Figure 1.1 Group and plant controllers

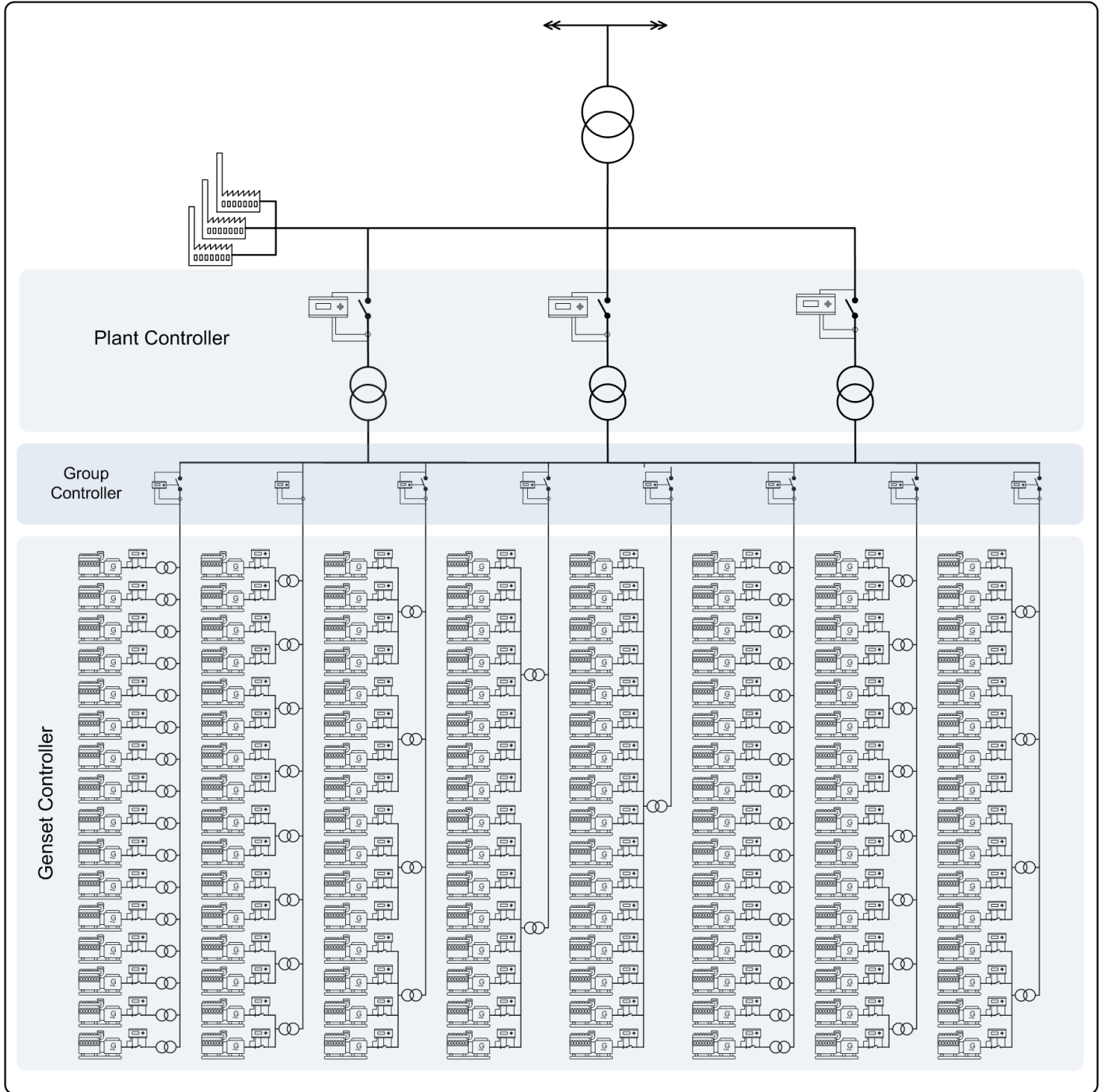

1.3 General functions

1.3.1 Functions

Control functions	Genset GB & MB	Genset GB only	Mains	BTB
Synchronising				
• Static	GB only	x	-	-
• Dynamic	x	x	x	x
No. of breakers/contactors to be controlled	2	1	0, 1 or 2	1
Run coil	x	x		
Stop coil with wire break	x	x		
Relay outputs for speed control	x	x		

Genset functions	Genset GB & MB	Genset GB only
Start/stop sequences	x	x
Run coil	x	x
Stop coil with wire break	x	x
Relay outputs for speed control	x	x
Close before excitation (fast synchronisation)	x	x
Temperature-dependent cooling down		
Time-based cooling down	x	x
Emergency cooling down		
Engine running hours counter, emergency, normal		
Start attempt counter	x	x
Maintenance counter		
Power derate	x	x
Nominal settings for rental gensets	x	x
Lube oil renewal	x	x
Fan control of 4 fans	x	x
Fuel pump logic	x	x
Engine block heater control	x	x

Mains functions	Genset GB & MB	Mains
Short time parallel	x	x
Mains support (frequency and voltage)	x	x

General functions	Genset GB & MB	Genset GB only	Mains	BTB
Breaker operation counter	x	x	x	x
Event log with real-time clock				
Alarm log with real-time clock	x	x	x	x
Battery crank test log with real-time clock				

General functions	Genset GB & MB	Genset GB only	Mains	BTB
Command timers	x	x	x	x
Pulse input counters	x	x	x	x
Current thermal demands	x	x	x	x
kWh meter Day/week/month/total	x	x	x	x
kvarh meter Day/week/month/total	x	x	x	x
Battery test, crank or asymmetry	x	x		x*
Master clock	x	x		

*Note: Only asymmetric supervision.

Utility software functions	Genset GB & MB	Genset GB only	Mains	BTB
USB interface to PC	x	x	x	x
Free PC utility SW (Windows)	x	x	x	x
Permission settings in PC utility SW for limited SCADA access	x	x	x	x
Password-protected setup	x	x	x	x
Customisable display views	x	x	x	x

M-Logic	Genset GB & MB	Genset GB only	Mains	BTB
Logic configuration tool for plant customising	x	x	x	x
Selectable input events, for example, plant status	x	x	x	x
Selectable output events, for example, plant commands	x	x	x	x

1.3.2 Protections

AC protections	No. of	ANSI	Genset	Mains	BTB
Reverse power	x2	32R	x	x	
Short circuit	x2	50P	x	x	
Over-current	x4	51	x	x	x
Voltage-dependent over-current	x1	51V	x	x	x
Over-voltage	x2	59P	x	x	x
Under-voltage	x3	27P	x	x	x
Over-frequency	x3	81O	x	x	x
Under-frequency	x3	81U	x	x	x
Unbalanced voltage	x1	47	x	x	x
Unbalanced current	x1	46	x	x	x
Under-excitation or var import	x1	32RV	x	x	x

AC protections	No. of	ANSI	Genset	Mains	BTB
Over-excitation or var import	x1	32FV	x	x	x
Overload	x5	32F	x	x	x
Busbar/mains over-voltage	x3	59P	x	x	x
Busbar/mains under-voltage	x4	27P	x	x	x
Load shed, three levels					
via current	x3	51	x	x	
via busbar frequency	x3	81	x	x	
via overload	x3	32	x	x	
via fast overload	x3	32	x	x	
Busbar/mains over-frequency	x3	81O	x	x	x
Emergency stop	x1	1	x		
Overspeed	x2	12	x		
Low auxiliary supply	x1	27DC	x	x	x
High auxiliary supply	x1	59DC	x	x	x
Generator breaker external trip	x1	5	x		
Tie/mains breaker external trip	x1	5	x*	x	x
Synchronisation failure alarms		25	x	x	x
Breaker open failure		52BF	x	x	x
Breaker close failure		52BF	x	x	x
Breaker position failure		52BF	x	x	x
Close before excitation failure	x1	48	x		
Phase sequence error	x1	47	x	x	x
Deload error	x1	34	x		
Crank failure	x1	48	x		
Running feedback error	x1	34	x		
Start failure	x1	48	x		
Hz/V failure	x1	53	x		
Stop failure	x1	48	x		
Stop coil, wire break alarm	x1	5	x		
Engine heater	x1	26	x		
Not in Auto	x1	34	x	x	x

*Note: Only if the genset controller controls the mains breaker.

General protections	No. of	Genset	Mains	BTB
Multi-config. inputs with wire break alarms, three inputs	x2	x	x	x
MPU wire break	x1	x		
Battery test alarm	x1	x		
Max. ventilation/radiator fan	x2	x	x	x
Fuel fill check	x1	x		

1.3.3 Application emulation

Use the emulation tool of the AGC to verify and test the functionality. The emulation tool makes it possible to test most of the functions, for example, plant modes and logics, breaker handling, mains and generator operation. Emulation only requires a DC supply and CAN bus between the controllers.

Application emulation is useful for training, customising plant requirements, and testing basic functionality.

In a power management system, the entire plant can be controlled using the PC Utility Software tool, if there is a TCP/IP connection to one of the AGC controllers.

1.4 Power management

The power management system ensures that the controllers work together to control all breakers and all gensets. Power management can ensure safety, fuel optimisation, easy implementation of plant logic, and so on.

1.4.1 Safe power management

Multi-master system

AGC power management is designed as a multi-master system for increased reliability. In a multi-master system all vital data is transmitted between the AGCs, giving all controllers knowledge of the present power management status (calculations and position) in the application. This philosophy makes the application immune to failing master controllers and makes the AGC suitable for all types of applications, that is emergency standby/critical power applications.

Redundant CAN bus

In critical power and emergency standby applications requiring extra operation reliability, redundant CAN bus communication lines can be used. This ensures reliable CAN bus communication for power management if one of the CAN lines is damaged.

Redundant controller

With the Critical Power option (T1) it is possible to have redundant controllers in the application. The redundant controller is connected on the CAN line as a hot standby unit and is therefore always updated with the system status and ready to become the primary controller.

1.4.2 Applications

The AGC can include power management (option G4, G5, or G8) and extended power management (option G7). With power management, the AGC can handle simple or advanced applications for a variety of power plant projects. Applications include synchronising gensets, critical power, emergency standby, and power production.

For power management (option G4, G5 or G8), the following can be controlled:

- 32 gensets and/or mains with breakers (ID 1 to 32)
- 8 bus tie breakers on the generator bus or load bus (ID 33 to 40)
- 16 automatic sustainable controllers ASC-4 (solar and/or battery) (ID 25 to 40, ASC SW 4.10.0 or greater)
- 8 automatic load controllers ALC-4 (ID 25 to 40, ALC SW 4.10.0 or greater)

For extended power management (option G7), the following can be controlled:

- Up to 992 gensets with breakers
- 8 bus tie breakers on the group bus (ID 33 to 40)
- 8 automatic sustainable controllers ASC-4 (solar) (ID 33 to 40)
- 32 mains, group and/or plant controllers with breakers (ID 1 to 32)

The complete power management system can easily be monitored from the PC utility SW through a graphical supervision page. Running status, hours in operation, breaker status, condition of mains and busbars and fuel consumption are just some of the values that are presented.

1.4.3 Plant modes

The plant can be divided by one to eight bus tie breakers. This makes it possible to run the plant with different plant modes. For example, for test purposes, or when splitting up the load in primary and secondary loads.

1.4.4 Power management functions

Controller Requires option	Genset G4/G5/G8	Mains G5	BTB G4/G5
Multi-master system	X	X	X
Redundant CAN bus	X	X	X
Load management	X	X	X
Load-dependent start/stop	X		
Priority selection:			
• Manual			
◦ Absolute/relative			
• Running hours	X		
◦ Absolute/relative			
◦ Total/trip/load profiled			
• Fuel optimisation			
Neutral earth relay (Ground relay)	X		
Safety stop of genset	X		
N + X (Secured mode) (Start 1 to 8 extra generators)	X		
Asymmetric LS for optimal generator load level	X		
Base load running for maintenance (island plants)	X		
Analogue load sharing for backup with option G3	X		
Easy connect (for genset application setup)	X		
Short-time parallel (in same controller (MB/TB))		X	
ATS control		X	
Plant PF control		X	
Mains feeder control, feeders paralleled		X	
Mains feeder control, main-tie-main for critical power		X	
Section power control			X

1.4.5 Easy configuration of single-line diagrams

The application setup is easily configured using a PC and the DEIF PC utility software.

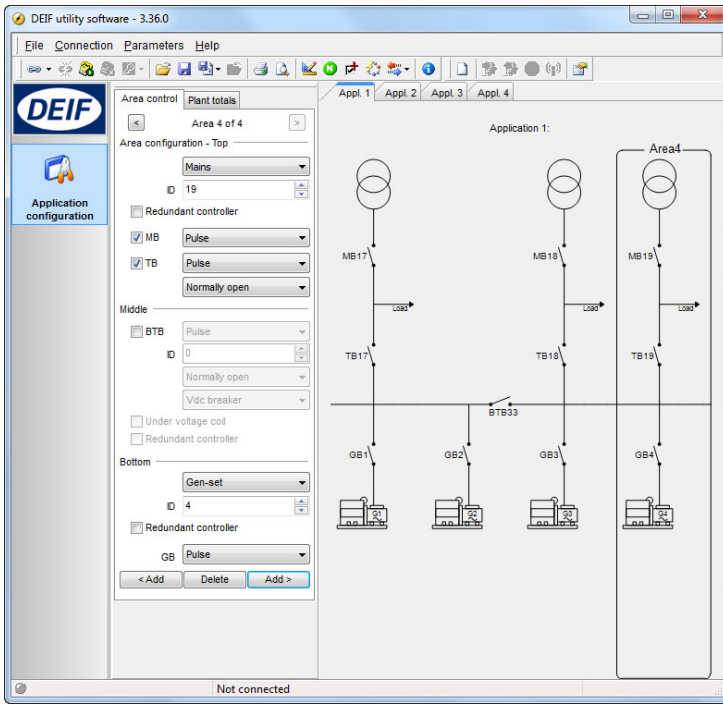

The basic plant control is set up by a few basic plant conditions, including mains feeder handling and operation of the generators.

1.5 Hardware

1.5.1 Inputs and outputs

The number of inputs and outputs in the AGC depend on the option selection. This table includes the number of I/Os in the genset controller (with no options). The four outputs of the governor/AVR card in slot #4 are not included.

In-/outputs	Fixed (not configurable)	Configurable
Multi-selectable inputs	0	3
Digital inputs	2 for breaker ON/OFF feedbacks, 1 E-stop If MB is used: 4 for breaker ON/OFF feedbacks, 1 E-stop	9 If MB is used: 7
RPM (MPU)	0	1
Relays for engine control	4 (Start prepare, Crank, Stop, Run)	0
Relays for breaker control	2 If MB is used: 4	2 If MB is used: 0
Relay	1 (Status/watchdog)	1
Open collector outputs	0	2

1.5.2 Terminal overview

This terminal strip overview shows the terminals of an AGC with commonly used HW options.

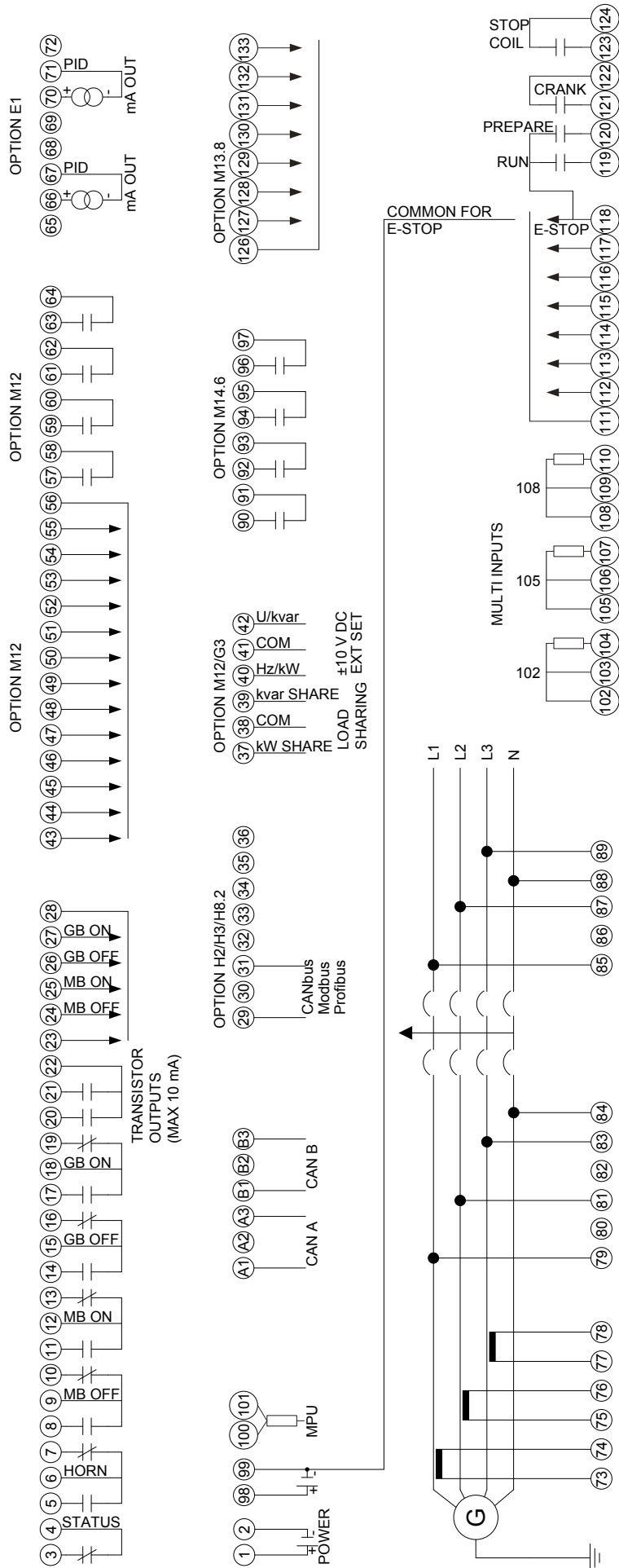

2. Optional hardware

2.1 AGC-4 hardware options

2.1.1 Hardware options and slot numbers

Controller slot numbers and terminals

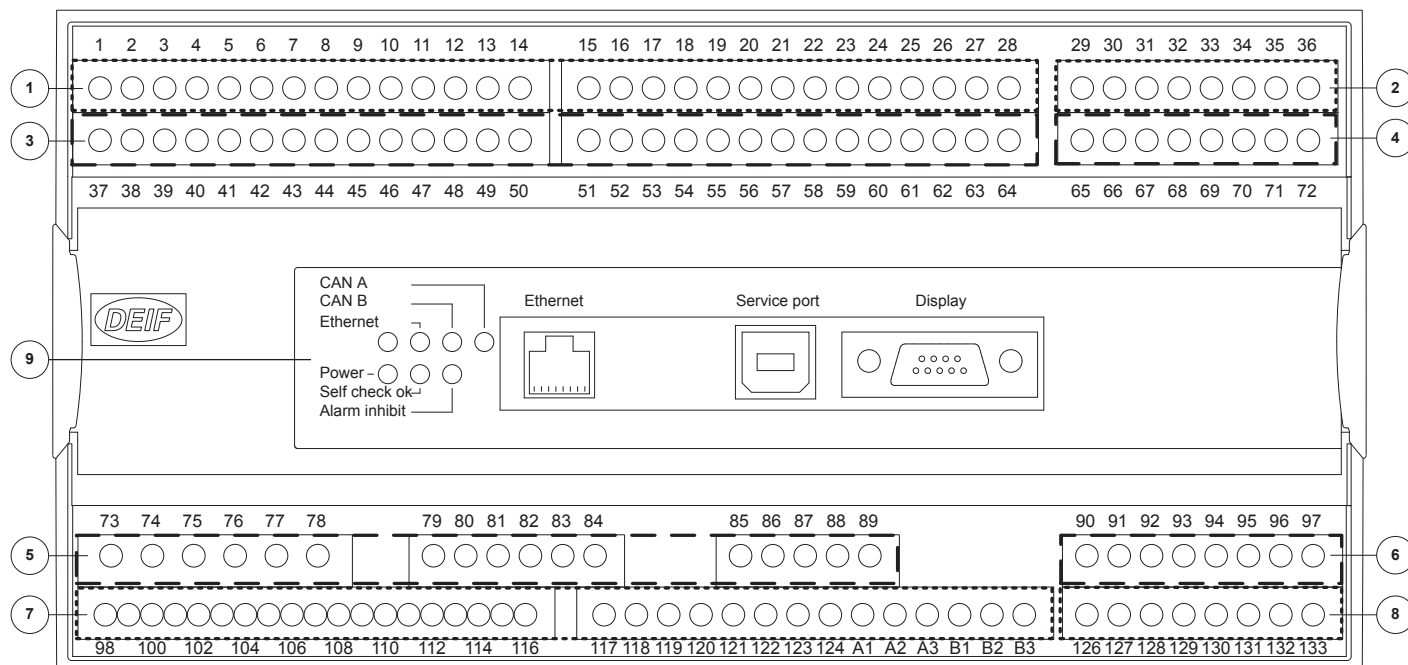

There can only be one hardware option in each slot. For example, it is not possible to select option H2 and option H3 at the same time, because both options require a PCB in slot #2.

Slot #	Option	Description
1		Terminal 1-28, power supply
	Standard	8 to 36 V DC supply, 11 W; 1 x status output relay; 5 x relay outputs; 2 x pulse outputs (kWh, kvarh or configurable open collector outputs); 5 x digital inputs
2		Terminal 29-36, communication
	H2	Modbus RTU (RS-485)
	H3	Profibus DP
	H5.2	J1939 engine comm. and MTU (ADEC/MDEC)
	H6.2	Modbus RTU, RS-485 (Modbus requires option H2)
	H8.2**	External I/O modules
	H9	Modbus RS-232 for modem
	H12.2**	Dual CAN includes H5 (engine communication) and H8 (external IO)
	M13.2	7 x binary inputs
	M14.2	4 x relay outputs
3		Terminal 37-64, in-/outputs/load sharing
	M12	13 x digital inputs; 4 x relay outputs Software option G3 (analogue load sharing) adds: <ul style="list-style-type: none"> 1 x active power load sharing

Slot #	Option	Description
		<ul style="list-style-type: none"> 1 x reactive power load sharing (requires D1) 1 x f/P set point transducer 1 x U/Q set point transducer (requires D1)
4		Terminal 65-72, governor, AVR, in-/outputs
	Standard	4 x relay
	E1	2 x +/-25 mA out
	E2	2 x 0(4) to 20 mA out
	EF2	1 x +/-25 mA out; 1 x 0(4) to 20 mA out
	EF4	1 x +/-25 mA out; 2 x relay
	EF5	1 x +/-25 mA out; 1 x PWM out; 2 x relay
	EF6	2 x +/-25 mA out; 1 x PWM out
5		Terminal 73-89, AC measuring
	Standard	3 x generator voltage + N; 3 x generator current; 3 x busbar/mains voltage + N
6		Terminal 90-97, in-/outputs
	F1	2 x 0(4) to 20 mA out, transducer
	M13.6	7 x digital inputs
	M14.6	4 x relay outputs
	M15.6	4 x 4 to 20 mA inputs
	M16.6	4 x Multi-inputs (4 to 20 mA or 0 to 5 V or Pt100)
7		Terminal 98-125, engine I/F
	Standard	8 to 36 V DC supply, 5 W; 1 x magnetic pickup (MPU); 3 x multi-inputs; 7 x digital inputs; 4 x relay outputs; 2 x CAN bus
	H7*	J1939 engine comm. and MTU ADEC
8		Terminal 126-133, engine communication, in-/outputs
	H5.8	J1939 engine comm. and MTU (ADEC/MDEC)
	H6.8	Cummins GCS
	H8.8**	External I/O modules
	H12.8**	Dual CAN includes H5 (engine communication) and H8 (external IO)
	H13	MTU ADEC M.501 (without SAM module) + J1939 engine comm. and MTU (ADEC/MDEC)
	M13.8	7 x digital inputs
	M14.8	4 x relay outputs
	M15.8	4 x 4 to 20 mA inputs
	M16.8	4 x Multi-inputs (4 to 20 mA or 0 to 5 V or Pt100)
9		LED I/F
	N	<ul style="list-style-type: none"> - Modbus TCP/IP - EtherNet/IP - SMS/e-mail alarms

*Note: If option H7 is selected, it is not possible to have options H5, H13 and H6 even though slot #8 is free.

**Note: It is only possible to select one of the options: H8.2 or H8.8 and H12.2 or H12.8.

The software options are listed under [Software options](#).

2.1.2 Variants

Type	Variant	Description	Item no.	Note
AGC-4	12	AGC-4 without display	2912410040-12	
AGC-4	13	AGC-4 w. display + J1	2912410040-13	One 3 m display cable is included as standard
AGC-4	07	AGC-4 BTB without display + G4	2912410040-07	
AGC-4	06	AGC-4 BTB w. display + G4 + J1	2912410040-06	One 3 m display cable is included as standard
AGC-4	09	AGC-4 Mains without display + A1 + G5	2912410040-09	
AGC-4	08	AGC-4 Mains w. display + A1 + G5 + J1	2912410040-08	One 3 m display cable is included as standard

2.1.3 Accessories

Accessory	Description	Option type	Note
J	Cables		
J1	Display cable with plugs, 3 m. UL94 (V1) approved	Other	
J2	Display cable with plugs, 6 m. UL94 (V1) approved	Other	
J4	PC cable for option N-programming (Ethernet cable crossed), 3 m. UL94 (V1) approved	Other	
J6	Display cable with plugs, 1 m. UL94 (V1) approved	Other	
J7	PC cable for utility software (USB), 3 m. UL94 (V1) approved	Other	
J8	Display CAN cable for DU-2 connection and 2 x plugs for cables for the Remote Maintenance Box	Other	RMB connector kit
L	Display gasket for IP54	Other	Standard is IP40
Q	Measurement accuracy	Hardware	
Q1	Verified class 0.5	Other	
X	Additional displays		
X2	Additional standard display (DU-2). CAN bus comm.	Other	Two options X2 can be ordered for each controller.
X3	Additional operator panel (AOP-1): 16 configurable LEDs and 8 configurable push-buttons	Other	
X4	Additional operator panel (AOP-2): 16 configurable LEDs, 8 configurable buttons and 1 status relay. CAN bus comm.	Other	Five options X4 can be ordered for each controller.
Y	Display layout	Hardware	
Y1	Engine and generator breaker control (island)	Other	For AGC Genset controller
Y3	Generator breaker and mains breaker control	Other	For AGC Genset controller
Y4	Tie breaker and mains breaker control	Other	For AGC Mains controller
Y5	Bus tie breaker control	Other	For AGC BTB controller

Accessory	Description	Option type	Note
Y8	Group control	Other	For AGC Group controller
Y9	Plant control	Other	For AGC Plant controller

2.2 TDU 107 touch display unit

2.2.1 Overall description

TDU 107 is a preprogrammed touch screen solution for connection to DEIF's AGC-4 controllers via the Ethernet port*.

*The AGC-4 requires Modbus TCP (hardware option N) for connection.

The displays provide user-friendly touch screen control, visualisation and graphical overviews with a quality display that is easily readable even at sharp angles.

Combines both a HMI display and 6 AOP (Additional Operator Panel) on one device. Easy to use icon driven HMI providing fast access and configurable instrument pages.

The colour graphic screen shows status and info messages. The screen also allows access to live data, and alarm management. Advanced event log page allows filtering and merging of log events. With the right authorisation, the operator can also check and/or change the input/output and parameter configuration.

The supervision feature provides an instant overview of the system and current operation.

Both the TDU 107 Core and TDU 107 Extended provide Tier 4 final support.

Tier 4 final support

- Tier 4 icons on dashboard.
- DM-1 and DM-2 pages.
- Extended dialogue texts including number of occurrences.
- Jumps to the exhaust after-treatment dashboard for any status change.

Display choices

TDU 107 is available in two versions, Core and Extended.

TDU 107 Core

- Operating temperature range 0 °C to +50 °C (vertical installation).
- Resistive touch screen.

TDU 107 Extended

- Operating temperature range -20 °C to +60 °C (vertical installation).
- Capacitive touch screen.
- VNC support (Remote access).
- Ethernet switch (Bridged between 2 ports).

2.3 DU-2 display unit

See the German data sheet for the AGC-4 GER display unit folios.

2.3.1 Option Y1 (Island engine and GB control)

For AGC Genset controllers in island applications and for synchronising gensets.

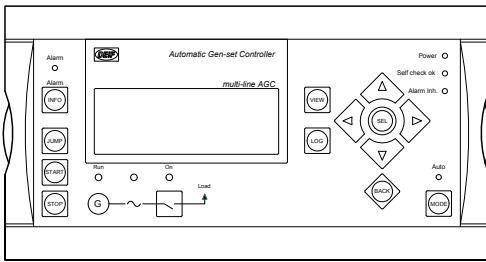

2.3.2 Option Y3 (Engine, GB and MB control)

For AGC Genset controllers. Typically used by rental companies or for single genset applications with one mains.

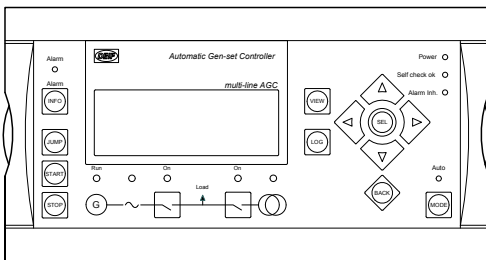

2.3.3 Option Y4 (TB and MB control)

For AGC Mains controllers.

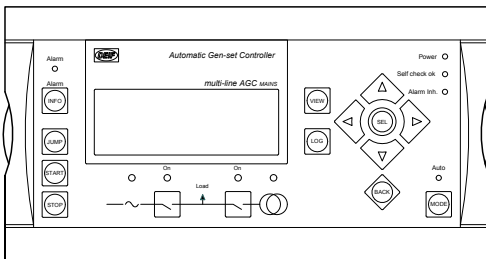

2.3.4 Option Y5 (Bus tie breaker control)

For AGC BTB controllers.

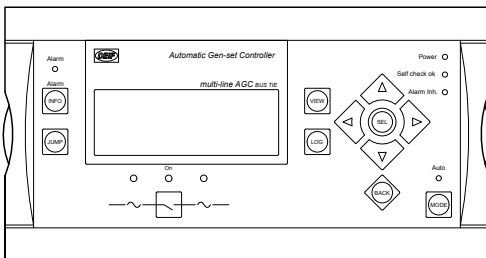

2.3.5 Option Y8 (Group control)

For AGC Group controllers.

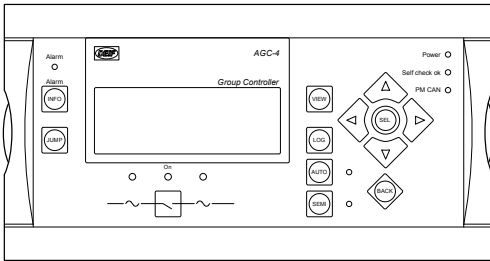

2.3.6 Option Y9 (Plant control)

For AGC Plant controllers.

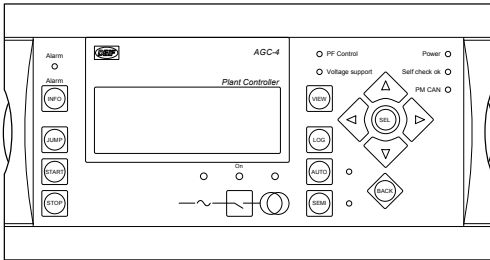

2.3.7 Option X3 (AOP-1)

Additional operator panel for plant and/or genset control and status/alarm indication.

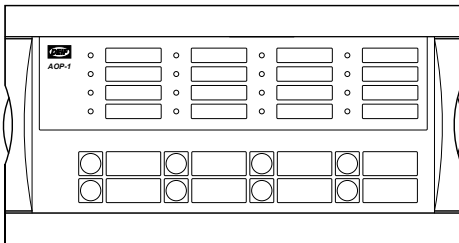

2.3.8 Option X4 (AOP-2)

Additional operator panel for plant and/or genset control and status/alarm indication (maximum five per AGC).

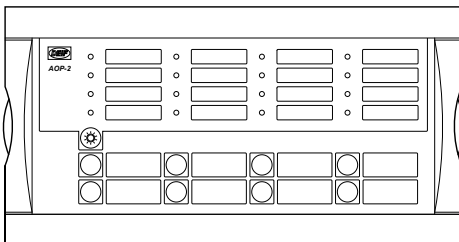

3. Optional software

3.1 Software options

Option	Description*	Slot no.	Type	Notes
A	Loss of mains protection package			
A1	Time-dependent under-voltage (27t) Under-voltage and reactive power low (27Q) Vector jump (78) df/dt (ROCOF) (81) Average busbar over-voltage protection		SW	
A4	Positive sequence (mains voltage low) (27)		SW	
A5	Directional over-current (67)		SW	
A10	Advanced protections <ul style="list-style-type: none"> • VDE AR-N 4110 compliant • VDE AR-N 4105 compliant • ENA EREC G99 compliant • EN 50549-1:2019 compliant 		SW	Requires options D1, A1, C2 and Q1
C2	Negative sequence voltage high (47) Negative sequence current high (46) Zero sequence voltage high (59) Zero sequence current high (50) Power-dependent reactive power (40) Inverse time over-current (51) (according to IEC 60255-151)		SW	
D	Voltage/var/cos phi control			Not available for AGC Mains and AGC BTB
D1	Constant voltage control (stand-alone) Constant reactive power control (parallel with mains) Constant power factor control (parallel with mains) Reactive load sharing (island paralleling with other generators)		SW	
G	Power management			
G3	Load sharing with analogue lines, and external analogue set points	3	SW	Requires hardware option M12.
G4	Power management, 32 gensets, 8 bus tie breakers, 8 ASC-4, 8 ALC-4	7	SW	Not with G5 or G8
G5	Power management, 32 gensets/mains, 8 bus tie breakers, 8 ASC-4, 8 ALC-4	7	SW	Not with G4 or G8
G7	Extended power management, up to 992 gensets, 31 groups, a plant	7	SW	
G8	Power management, 32 gensets (island mode), 8 ASC-4, 8 ALC-4	7	SW	Not with G4 or G5
H	Serial communication			

Option	Description*	Slot no.	Type	Notes	
H5		2, 8	HW/SW		
H7	Generic J1939 Caterpillar Cummins CM850/570 Detroit Diesel (DDEC) Deutz (EMR) Isuzu Iveco (NEF/CURSORS) John Deere (JDEC) Kohler MTU SmartConnect MTU ADEC MTU MDEC M302/M303	Perkins PSI/Power Solution Scania (EMS) Scania (EMS S6) Scania (EMS2 S8) Volvo Penta (EMS) Volvo Penta (EMS2) Volvo Penta (EMS2.4)	7	SW	Not with H5, H6, H12 or H13 Option H7 is a limited version of H5. Some protocols and advanced features are not supported. See the Option H5/H7/H12/H13 manual.
H12		2, 8	HW/SW	H12 is a dual CAN, which includes H5 and H8. H13 can be added. H5, H7 and H8 cannot be added.	
H13	MTU ADEC M.501 + same engine types as H5	8	HW/SW		
I	Application emulation				
I1	Emulation, PC-controlled emulation of your application		SW		
T	Special applications				
T1	Critical power, redundant controller, short-circuit limitation		SW	Option T1 is only functional if G4, G5 or G8 is already selected.	
T2	CANbus communication with DEIF Digital AVR's DVC 310, DVC 550 and Nidec D510		SW	Option T2 requires H5, H12 or H13, and D1.	
T3	CANbus communication with Nidec Digital AVR D550		SW	Option T3 requires H5, H12 or H13, and D1.	
T4	RMB with multiple gensets		SW		
	Language variants				
CYD	Cyrillic display		HW/SW	To display Russian characters.	
V0108	German display		HW/SW	For AGC-4 GER.	

*Note: ANSI number as per IEEE Std C37.2-1996 (R2001) in parenthesis.

4. Compatible products

4.1 Touch display unit: TDU 107

TDU 107 is a pre-programmed touch screen display for the AGC-4 controllers. For more information, see www.deif.com/products/tdu-107

4.2 Remote monitoring service: Insight

Insight is a responsive remote monitoring service. It includes real-time genset data, a customisable dashboard, GPS tracking, equipment and user management, email and/or SMS alerts, and cloud data management. For more information, see www.deif.com/products/insight

4.3 Digital voltage controller: DVC 550

DVC 550 is a digital AVR designed for alternators with SHUNT, AREP or PMG excitation. The DVC 550 monitors and regulates the alternator output voltage. AGC-4 can control all the DVC 550 features and receive fault information directly with the CAN bus communication. For more information, see www.deif.com/products/dvc-550

4.4 Additional inputs and outputs: CIO 116, 208 and 308

The CIO modules communicate with AGC-4 over CAN bus.

CIO 116 is a remote input expansion module. For more information, see www.deif.com/products/cio-116

CIO 208 is a remote output expansion module. For more information, see www.deif.com/products/cio-208

CIO 308 is a remote analogue input expansion module. For more information, see www.deif.com/products/cio-308

4.5 Other controllers

AGC 150 is compatible with AGC-4. For more information, see www.deif.com/products/agc-150

ASC-4 (Solar and Battery), the automatic sustainable controllers, are compatible with AGC-4. For more information, see www.deif.com/products/asc4-solar and www.deif.com/products/asc4-battery

ALC-4 (Automatic Load Controller) is compatible with AGC-4. For more information, see www.deif.com/products/alc-4

4.6 Remote maintenance box (RMB)

The Remote Maintenance Box (RMB) is a remote management tool for safe utilities maintenance. It can be used at transformer substations or other electrical installations when the operator panel must be close to the connection points. For more information, see www.deif.com/products/rmb

4.7 Other equipment

DEIF has a wide variety of other equipment that is compatible with AGC-4. This includes synchrosopes, meters, transducers, current transformers, power supplies, and battery chargers.

For more information, see www.deif.com

5. Technical information

5.1 Technical specifications

Accuracy	<p>Class 1.0 -25 to 15 to 30 to 70 °C Temperature coefficient: +/-0.2 % of full scale per 10 °C Class 0.5 with option Q1 Averaged frequency: +/-10 mHz, 15 to 30 °C, 45 to 65 Hz</p> <p>Positive, negative and zero sequence alarms: Class 1 within 5 % voltage unbalance Class 1.0 for negative sequence current Fast over-current: 3 % of 350 %*In Analogue outputs: Class 1.0 according to total range Option EF4/EF5: Class 4.0 according to total range To IEC/EN60688</p>
Operating temperature	<p>-25 to 70 °C (-13 to 158 °F) -25 to 60 °C (-13 to 140 °F) if Modbus TCP/IP (option N) is available in the controller. (UL/cUL Listed: Max. surrounding air temperature: 55 °C/131 °F)</p>
Storage temperature	-40 to 70 °C (-40 to 158 °F)
Climate	97 % RH to IEC 60068-2-30
Operating altitude	<p>0 to 4000 m above sea level Derating 2001 to 4000 m above sea level: Max. 480 V AC phase-phase 3W4 measuring voltage Max. 690 V AC phase-phase 3W3 measuring voltage</p>
Measuring voltage	<p>100 to 690 V AC +/-20 % (UL/cUL Listed: 600 V AC phase-phase) Consumption: Max. 0.25 VA/phase</p>
Measuring current	<p>-/1 or -/5 A AC (UL/cUL Listed: from CTs 1-5 A) Consumption: Max. 0.3 VA/phase</p>
Current overload	<p>4 x I_n continuously 20 x I_n, 10 sec. (max. 75 A) 80 x I_n, 1 sec. (max. 300 A)</p>
Measuring frequency	30 to 70 Hz
Aux. supply	<p>Terminals 1 and 2: 12/24 V DC nominal (8 to 36 V DC operational). Max. 11 W consumption Battery voltage measurement accuracy: ±0.8 V within 8 to 32 V DC, ±0.5 V within 8 to 32 V DC @ 20 °C Terminals 98 and 99: 12/24 V DC nominal (8 to 36 V DC operational). Max. 5 W consumption 0 V DC for max. 10 ms when coming from at least 24 V DC (cranking dropout) The aux. supply inputs are to be protected by a 2 A slow blow fuse. (UL/cUL Listed: AWG 24)</p>
Digital inputs	<p>Optocoupler, bi-directional ON: 8 to 36 V DC Impedance: 4.7 kΩ OFF: <2 V DC</p>
Analogue inputs	<p>-10 to +10 V DC: Not galvanically separated. Impedance: 100 kΩ (analogue load sharing lines) 0(4) to 20 mA: impedance 50 Ω. Not galvanically separated (M15.X)</p>
RPM	RPM (MPU): 2 to 70 V AC, 10 to 10000 Hz, max. 50 kΩ
Multi-inputs Engine interface board slot #7	<p>0(4) to 20 mA: 0 to 20 mA, +/-1 %. Not galvanically separated Digital: Max. resistance for ON detection: 100 Ω. Not galvanically separated Pt100/1000: -40 to 250 °C, +/-1 %. Not galvanically separated. To IEC/EN60751 RMI: 0 to 1700 Ω, +/-2 %. Not galvanically separated V DC: 0 to 40 V DC, +/-1 %. Not galvanically separated</p>

Multi-inputs (M16.X)	0(4) to 20 mA: 0 to 20 mA, +/-2 %. Not galvanically separated Pt100: -40 to 250 °C, +/-2 %. Not galvanically separated. To IEC/EN60751 V DC: 0 to 5 V DC, +/-2 %. Not galvanically separated
Relay outputs	Electrical rating: 250 V AC/30 V DC, 5 A. (UL/cUL Listed: 250 V AC/24 V DC, 2 A resistive load) Thermal rating @ 50 °C: 2 A: Continuously. 4 A: $t_{on}= 5 \text{ sec.}$, $t_{off} = 15 \text{ sec.}$ (Controller status output: 1 A)
Open collector outputs	Supply: 8 to 36 V DC, max. 10 mA (terminal 20, 21, 22 (com))
Analogue outputs	0(4) to 20 mA and +/-25 mA. Galvanically separated. Active output (internal supply). Load max. 500 Ω. (UL/cUL Listed: Max. 20 mA output) Update rate: transducer output: 250 ms. Regulator output: 100 ms
Load sharing lines	-5 to 0 to +5 V DC. Impedance: 23.5 kΩ
Galvanic separation	Between AC voltage and other I/Os: 3250 V, 50 Hz, 1 min. Between AC current and other I/Os: 2200 V, 50 Hz, 1 min. Between analogue outputs and other I/Os: 550 V, 50 Hz, 1 min. Between digital input groups and other I/Os: 550 V, 50 Hz, 1 min.
Response times (delay set to minimum)	<p>Busbar: Over-/under-voltage: <50 ms Over-/under-frequency: <50 ms Voltage unbalance: <250 ms</p> <p>Generator: Reverse power: <250 ms Over-current: <250 ms Fast over-current: <40 ms Directional over-current: <150 ms Over-/under-voltage: <250 ms Over-/under-frequency: <350 ms Overload: <250 ms Current unbalance: <250 ms Voltage unbalance: <250 ms Reactive power import: <250 ms Reactive power export: <250 ms Voltage-dependent I>: <250 ms Negative sequence I: <500 ms Negative sequence U: <500 ms Zero sequence I: <500 ms Zero sequence U: <500 ms Overspeed: <500 ms Digital inputs: <250 ms Emergency stop: <200 ms Multi-inputs: 800 ms Wire failure: <600 ms</p> <p>Mains: df/dt (ROCOF): <130 ms (4 periods) Vector jump: <40 ms Positive sequence: <60 ms Time-dependent under-voltage (Low Voltage Ride Through), $U_{t<}$: < 55 ms Time-dependent under-voltage (Low Voltage Ride Through) if SYM or ASYM detection is chosen, $U_{t<}$: < 70 ms Time-dependent over-voltage (High Voltage Ride Through), $U_{t>}$: < 55 ms Under-voltage and reactive power low, $U_{Q<}$: <250 ms</p>
Mounting	DIN-rail mount or base mount with six screws Tightening torque: 1.5 N·m
Safety	To EN 61010-1, installation category (over-voltage category) III, 600 V, pollution degree 2 To UL 508 and CSA 22.2 no. 14-05, over-voltage category III, 600 V, pollution degree 2

EMC/CE	To EN 61000-6-2, EN 61000-6-4, IEC 60255-26.
Vibration	3 to 13.2 Hz: 2 mm _{pp} . 13.2 to 100 Hz: 0.7 g. To IEC 60068-2-6 & IACS UR E10 10 to 58.1 Hz: 0.15 mm _{pp} . 58.1 to 150 Hz: 1 g. To IEC 60255-21-1 Response (class 2) 10 to 150 Hz: 2 g. To IEC 60255-21-1 Endurance (class 2) 3 to 8.15 Hz: 15 mm _{pp} . 8.15 - 35 Hz 2g. To IEC 60255-21-3 Seismic (class 2)
Shock (base mount)	10 g, 11 ms, half sine. To IEC 60255-21-2 Response (class 2) 30 g, 11 ms, half sine. To IEC 60255-21-2 Endurance (class 2) 50 g, 11 ms, half sine. To IEC 60068-2-27
Bump	20 g, 16 ms, half sine. To IEC 60255-21-2 (class 2)
Material	All plastic materials are self-extinguishing according to UL94 (V1)
Plug connections	Controller AC current: 0.2 to 4.0 mm ² stranded wire. (UL/cUL Listed: AWG 18) AC voltage: 0.2 to 2.5 mm ² stranded wire. (UL/cUL Listed: AWG 20) Relays: (UL/cUL Listed: AWG 22) Terminals 98-116: 0.2 to 1.5 mm ² stranded wire. (UL/cUL Listed: AWG 24) Other: 0.2 to 2.5 mm ² stranded wire. (UL/cUL Listed: AWG 24) Tightening torque: 0.5 N·m (5-7 lb-in) Service port: USB A-B DU-2 display 9-pole D-sub female Tightening torque: 0.2 N·m
Protection	Controller: IP20. Display: IP40 (IP54 with gasket: Option L). (UL/cUL Listed: Type Complete Device, Open Type). To IEC/EN 60529
Governors and AVRs	Multi-line 2 interfaces to all governors and AVRs using analogue, relay control or CAN-based J1939 communication See interfacing guide at www.deif.com
Approvals	UL/cUL Listed to UL508 Applies to VDE-AR-N 4105 See www.deif.com for the most recent approvals.
UL markings	Wiring: Use 60/75 °C copper conductors only Mounting: For use on a flat surface of type 1 enclosure Installation: To be installed in accordance with the NEC (US) or the CEC (Canada) AOP-2 Maximum ambient temperature: 60 °C Wiring: Use 60/75 °C copper conductors only Mounting: For use on a flat surface of type 3 (IP54) enclosure. Main disconnect must be provided by installer Installation: To be installed in accordance with the NEC (US) or the CEC (Canada) DC/DC converter for AOP-2 Tightening torque: 0.5 Nm (4.4 lb-in) Wire size: AWG 22-14 Tightening torque: Panel door mounting 0.7 N·m, D-sub screw 0.2 N·m
Weight	Controller: 1.6 kg (3.5 lbs.) Option J1/J4/J6/J7: 0.2 kg (0.4 lbs.) Option J2: 0.4 kg (0.9 lbs.) Option J8: 0.3 kg (0.58 lbs.) DU-2 display: 0.4 kg (0.9 lbs.)

For the TDU 107 technical specifications, see the **TDU 107 Data sheet**. For more information, see www.deif.com/products/tdu-107

5.2 Dimensions

Figure 5.1 AGC-4 dimensions in mm (inches)

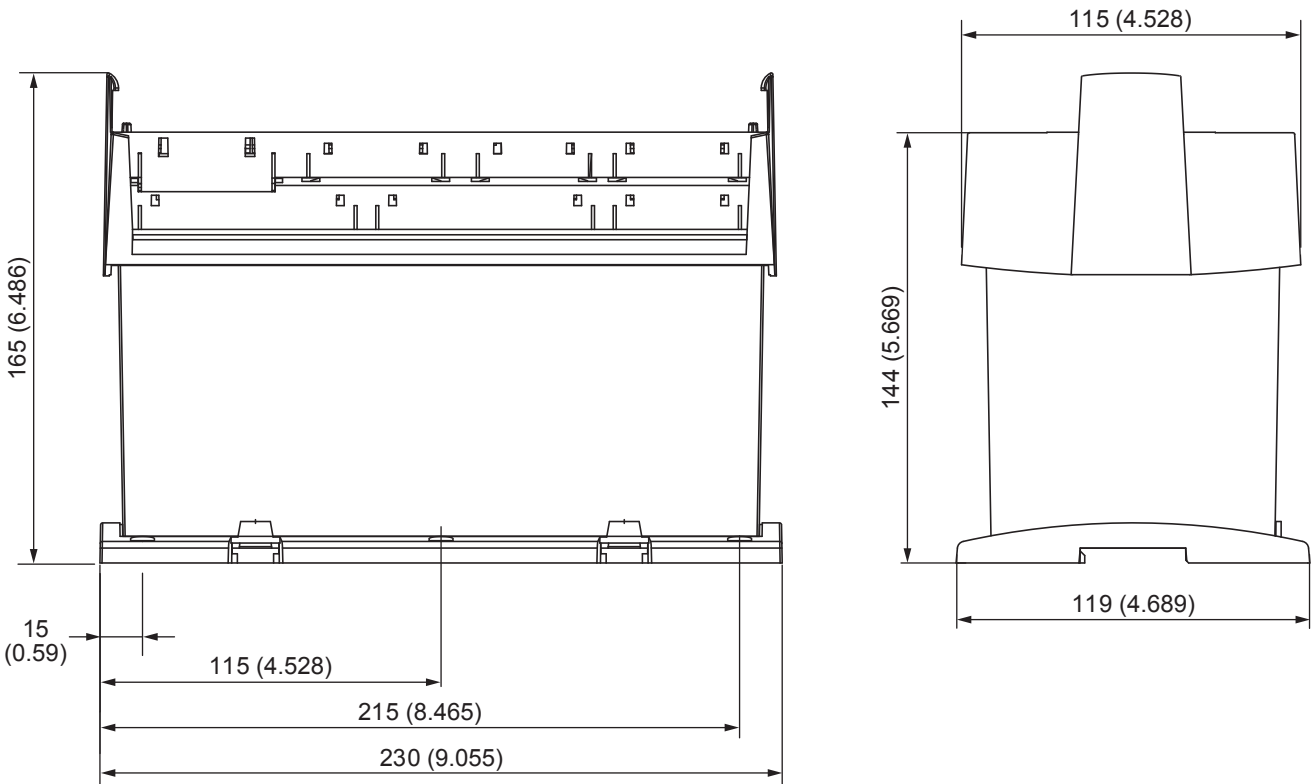
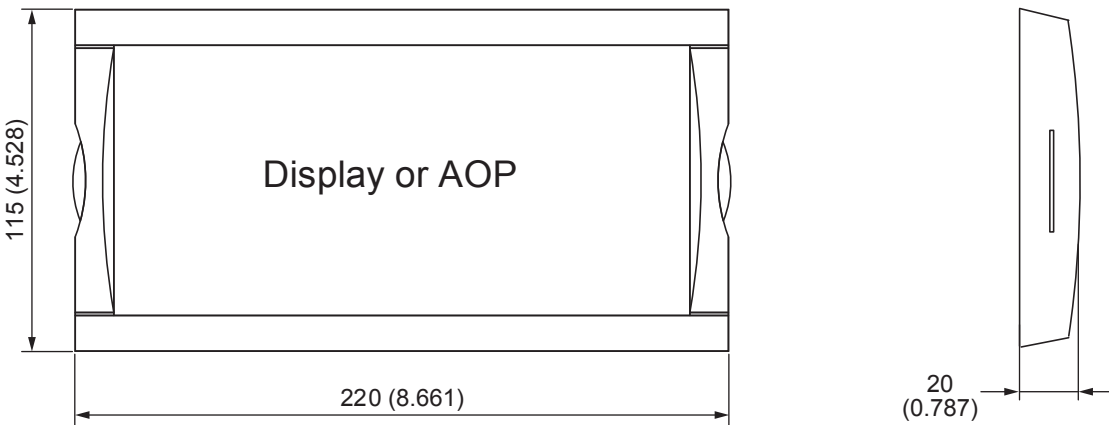

Figure 5.2 DU-2 dimensions in mm (inches)



For the TDU 107 dimensions, see the **TDU 107 Data sheet**.

6. Ordering information

6.1 Order specifications

Variants

Mandatory information			Additional options to the standard variant				
Item no.	Type*	Variant no.	Option	Option	Option	Option	Option

Example			Additional options to the standard variant				
Item no.	Type*	Variant no.	Option	Option	Option	Option	Option
2912410040-13	AGC-4 DG w. display + J1	13	C2	M12			

*Note: Specify the AGC type: DG/Mains/BTB/Group/Plant. By default, AGC Mains includes option G5. You must order AGC BTB with option G4 or G5.

Accessories

Mandatory information		
Item no.	Type	Accessory

Example		
Item no.	Type	Accessory
1022040065	Accessories for AGC-4	USB cable, 3 m (J7)

6.2 Disclaimer

DEIF A/S reserves the right to change any of the contents of this document without prior notice.

The English version of this document always contains the most recent and up-to-date information about the product. DEIF does not take responsibility for the accuracy of translations, and translations might not be updated at the same time as the English document. If there is a discrepancy, the English version prevails.

6.3 Copyright

© Copyright DEIF A/S. All rights reserved.